

Universal Instructions



LOWER CONTROL ARM SKIDS

Example -
6G 4Runner



Applications

Installation Instructions

These installation instructions apply to the following CBI Offroad Fab products

– *Universal Instructions*

IMPORTANT!

Thank you for purchasing this CBI Offroad Fab product. Please read through this entire document before proceeding with installation. If you are not confident in your mechanical skills, please seek the help of a professional to perform the installation. Check your packages immediately upon arrival to ensure that everything listed is included, and to check for damage during shipping. ***If anything is missing or damaged, or if you need technical assistance with any aspect of this installation, call CBI Offroad Fab at (208) 528-0664 as soon as possible.***

IMPORTANT!

All products built and designed by CBI Offroad Fab products are intended for off-road use and should be assembled, installed, and used according to CBI Offroad Fab's recommendations. CBI Offroad Fab products should be used safely with good judgment towards others and the environment. By installing CBI Offroad Fab products on your vehicle you assume all liability. CBI Offroad Fab will not be held liable for damages or loss associated with the installation or use of its products.

Be smart, use good judgement, don't overload your vehicle to the point of inferior handling and maneuverability!

***** WARNING*****

Neither the seller nor the manufacturer will be liable for any loss, damage, or injury directly or indirectly arising from the use of or inability to determine the use of these products. Before using, the user shall determine the suitability of the product(s) for its intended use(s), and the user shall assume all responsibility and risk in connection therewith.

Note for Dealers and Installers:

Read through all instructions before starting install. It is your responsibility to ensure instructions are given to the end user or client.

Contents

- [Parts Included](#)
- [Hardware Included](#)
- [Installation - General Instructions](#)
- [Installation - 3G Tundra/Sequoia](#)
- [Installation - 5G 4Runner](#)
- [Installation - 6G 4Runner/LC250](#)
- [Installation - 2G/3G Tacoma](#)
- [Installation - 4G Tacoma](#)
- [Installation - GX550](#)

Recommended Tools	
Personal & Vehicle Protection	Notes
Safety Glasses	
Special Tools	Notes
Installation Tools	Notes
Ratchet	
9/16" Wrench	
9/16" Socket	
3/4" Wrench	
3/4" Socket	
7/16" Wrench	
7/16" Socket	
Special Chemicals	Notes

Legend
Red Highlight - Use caution to prevent vehicle damage and/or injury.
Blue Highlight - Torque value callout.
Green Highlight - Special Chemicals
Bold/Underline - Important tips, tricks, or noteworthy steps for proper installation.

Parts Included

Driver and passenger lower control arm skidplates will be included.

- **Example image, skid plates received may look different.**

Hardware included.

- Carriage bolts, washers, nuts, and spacers
- **Carriage bolt length and quantity varies between model.** Quantity will coincide with amount of holes on bottom of LCA skid.

Example - Driver
6G 4Runner

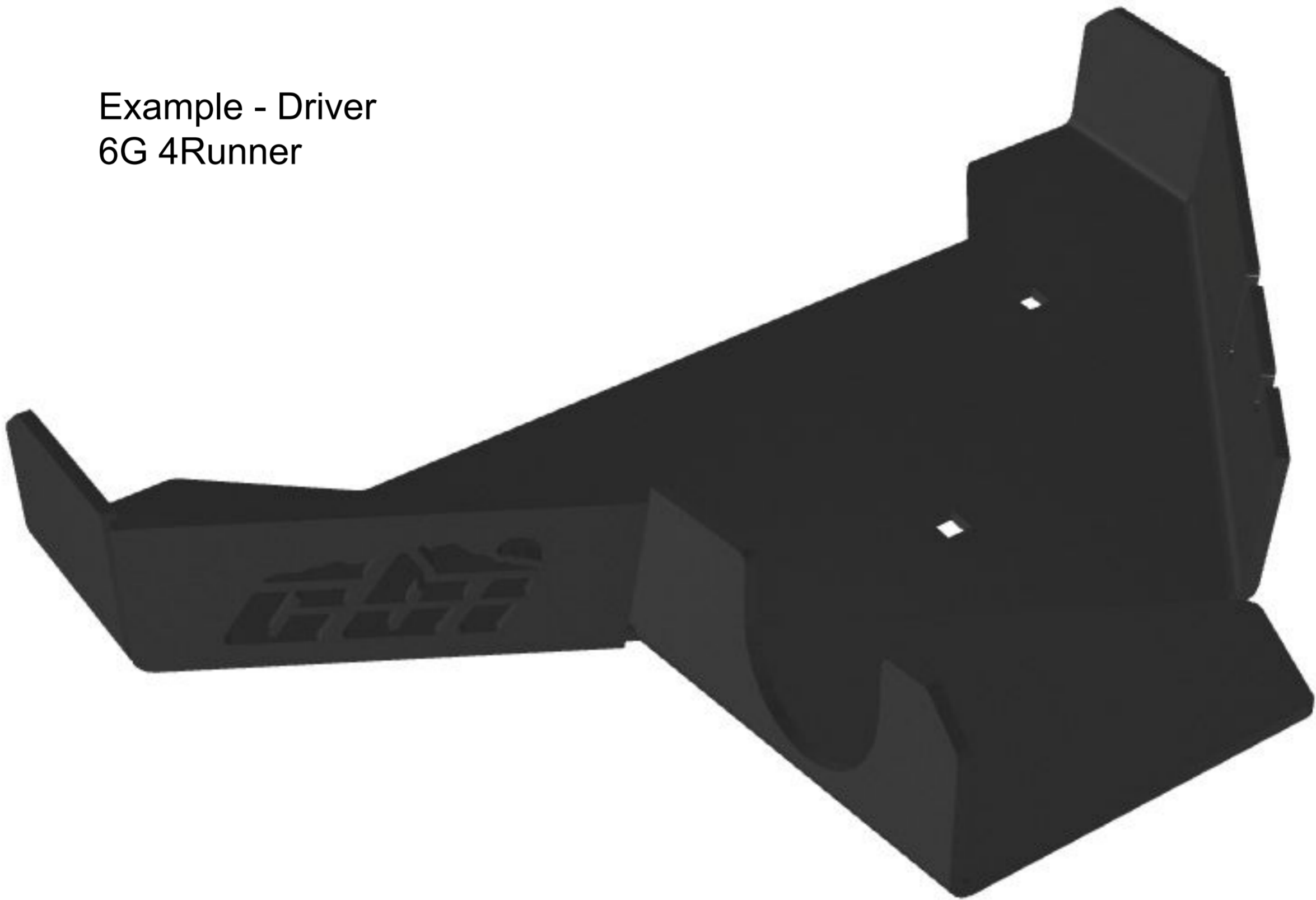

Example - Passenger
6G 4Runner

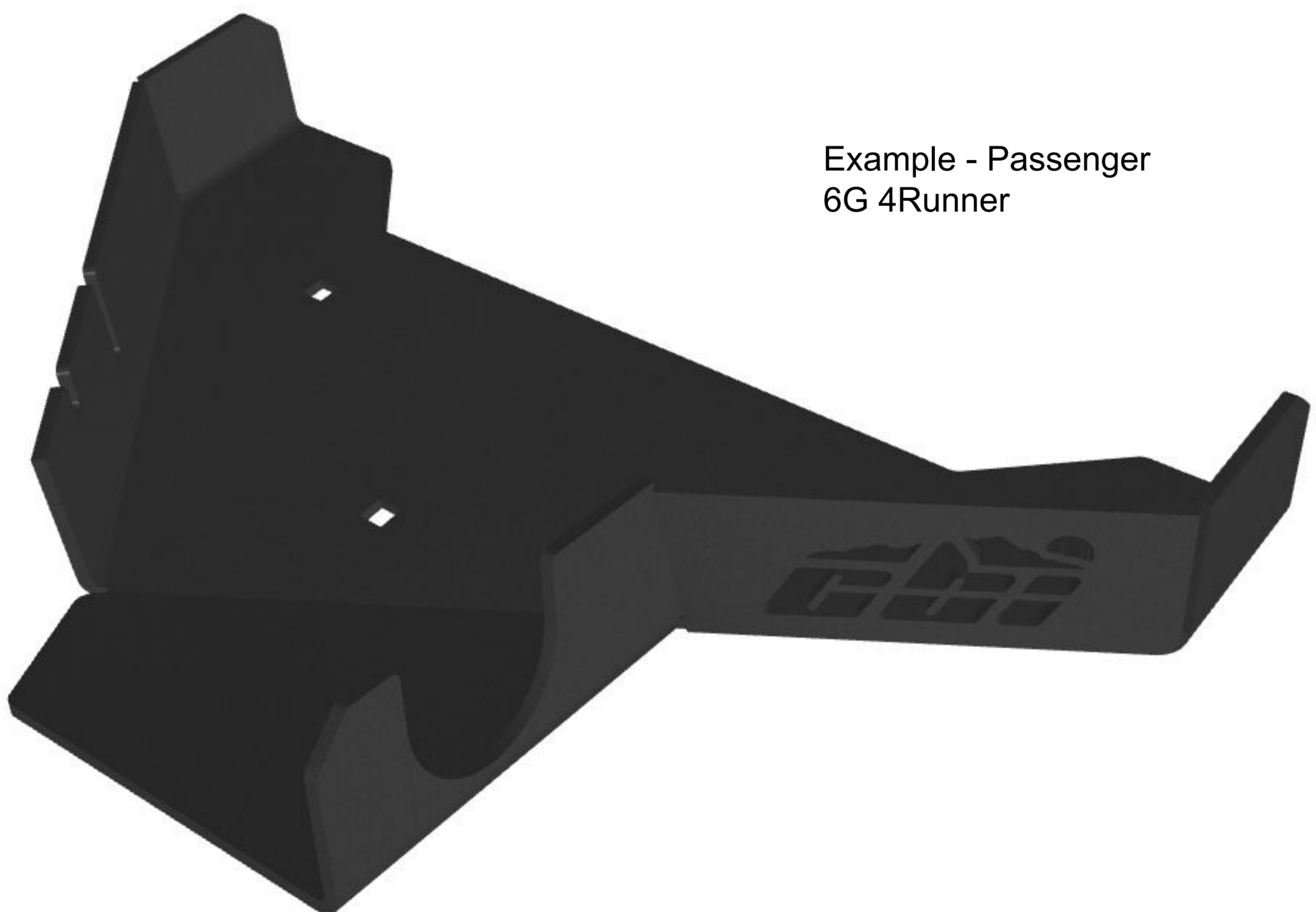

Hardware - Vehicle Specific

3rd Gen Toyota Tundra/Sequoia Lower Control Arm Skid Hardware

DESCRIPTION	QUANTITY	TORQUE LUBED	TORQUE DRY
1/2"-13 x 4-1/2" Steel Carriage Bolt Zinc	4		
1/2"-13 x 4" Steel Carriage Bolt Zinc	2		
1/2" x 1-3/8" Steel Flat Washer	2		
1/2"-13 Steel Nylon Insert Flange Nut Zinc	6	10 ft/lbs	10 ft/lbs
3/4" OD x .509" ID x 3/8" Long Plain Aluminum Spacer	4		

5th Gen Toyota 4Runner Lower Control Arm Skid Hardware

DESCRIPTION	QUANTITY	TORQUE LUBED	TORQUE DRY
3/8"-16 x 3-1/2" Steel Carriage Bolt Zinc	2		
3/8"-16 x 4" Steel Carriage Bolt Zinc	2		
3/8" x 13/16" Steel Flat Washer	4		
3/8"-16 Steel Nylon Insert Flange Nut Zinc	4	10 ft/lbs	10 ft/lbs

6th Gen Toyota 4Runner/LC250 Lower Control Arm Skid Hardware

DESCRIPTION	QUANTITY	TORQUE LUBED	TORQUE DRY
3/8"-16 x 4-1/2" Steel Carriage Bolt Zinc	6		
3/8" x 13/16" Steel Flat Washer	6		
3/8"-16 Steel Nylon Insert Flange Nut Zinc	6	10 ft/lbs	10 ft/lbs

Hardware - Vehicle Specific

3rd Gen Toyota Tacoma Lower Control Arm Skid Hardware

DESCRIPTION	QUANTITY	TORQUE LUBED	TORQUE DRY
3/8"-16 x 3" Steel Carriage Bolt Zinc	2		
3/8"-16 x 3-1/2" Steel Carriage Bolt Zinc	2		
1/4"-20 x 3" Zinc Finish ASTM A307 Grade A Round Head Carriage Bolt	2		
3/8" x Steel Square Washers for Strut Washer	4		
1/4" x 1-1/2" Steel Fender Washer	2		
1/4"-20 Stainless Steel Hex Nylon Insert Lock Nut Plain	2	5 ft/lbs	5 ft/lbs
3/8"-16 Steel Nylon Insert Flange Nut Zinc	4	10 ft/lbs	10 ft/lbs
Aluminum Spacer #AS50-14-40	2		

4th Gen Toyota Tacoma Lower Control Arm Skid Hardware

DESCRIPTION	QUANTITY	TORQUE LUBED	TORQUE DRY
3/8"-16 x 4" Steel Carriage Bolt Zinc	4		
3/8"-16 x 4-1/2" Steel Carriage Bolt Zinc	2		
3/8" x 1.250" OD Low Carbon Zinc Finish Steel Fender Washer	6		
3/8"-16 Steel Nylon Insert Flange Nut Zinc	6	10 ft/lbs	10 ft/lbs

Lexus GX 550 Lower Control Arm Skid Hardware

DESCRIPTION	QUANTITY	TORQUE LUBED	TORQUE DRY
3/8"-16 x 5" Carriage Bolt Zinc	6		
3/8" x 13/16" Steel Flat Washer	6		
3/8"-16 Steel Nylon Insert Flange Nut Zinc	6	10 ft/lbs	10 ft/lbs

Installation - General Instructions

Bolting Skid plate to lower control arm.

- Position the skid plate against the lower control arm, ensuring it follows the arm's profile and aligns with the through-holes.
- Run hardware and/or spacers through skid plate and control arm. Hardware and location called out in later slides.
- Torque 1/2" hardware (3/4" socket/wrench) and 3/8" hardware (9/16" and/or 3/4" socket/wrench) to **10 ft-lbs**. Torque 1/4" hardware (7/16" socket/wrench) to **5 ft-lbs**.

Warning: over tightening hardware will collapse lower control arm.

Perform Steps on driver and passenger sides of the vehicle.

Recommended - leave bolts loose until all hardware has been installed.

Example - Passenger
6G 4Runner

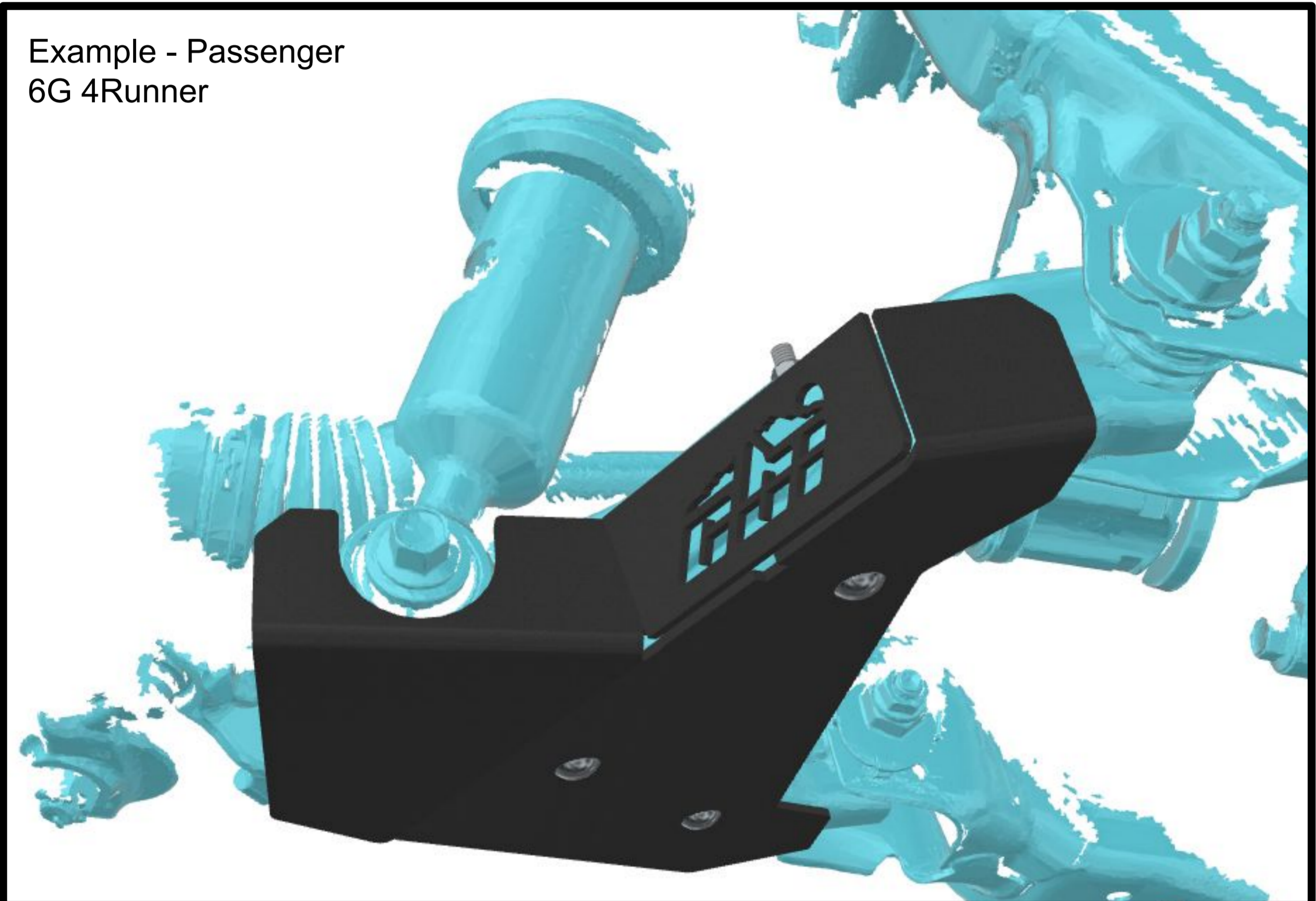

Example - Passenger
6G 4Runner

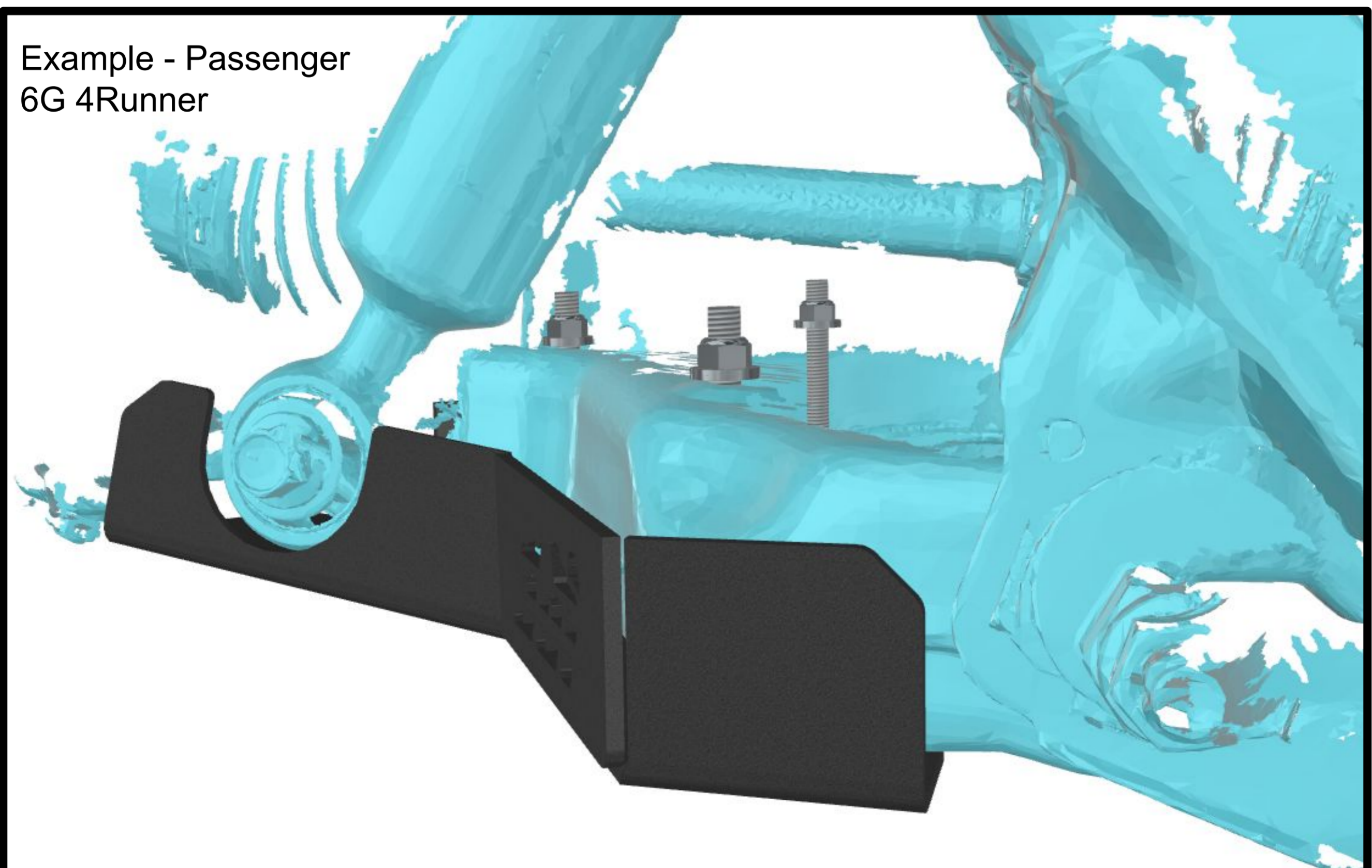

Installation - 3G Tundra/Sequoia

Hardware indicated with colored arrows. Quantity listed pertains to each side.

- QTY (2) 1/2" x 4 1/2" carriage bolt (white)
- QTY (1) 1/2" x 4" carriage bolt (yellow)
- QTY (3) 1/2" flange nut (red)
- QTY (1) 1/2" washer (blue)
- QTY (2) 3/8" Spacers (green)

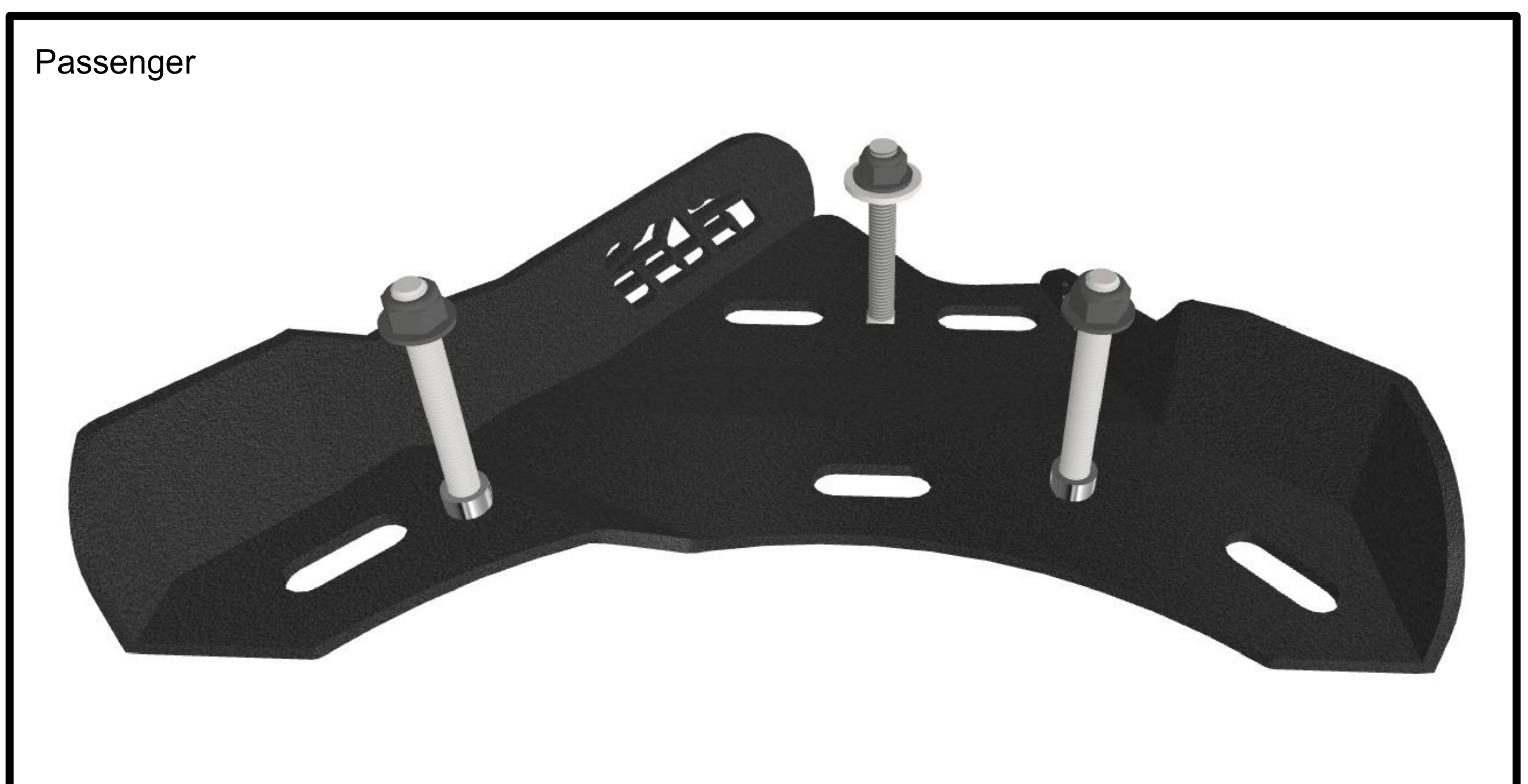
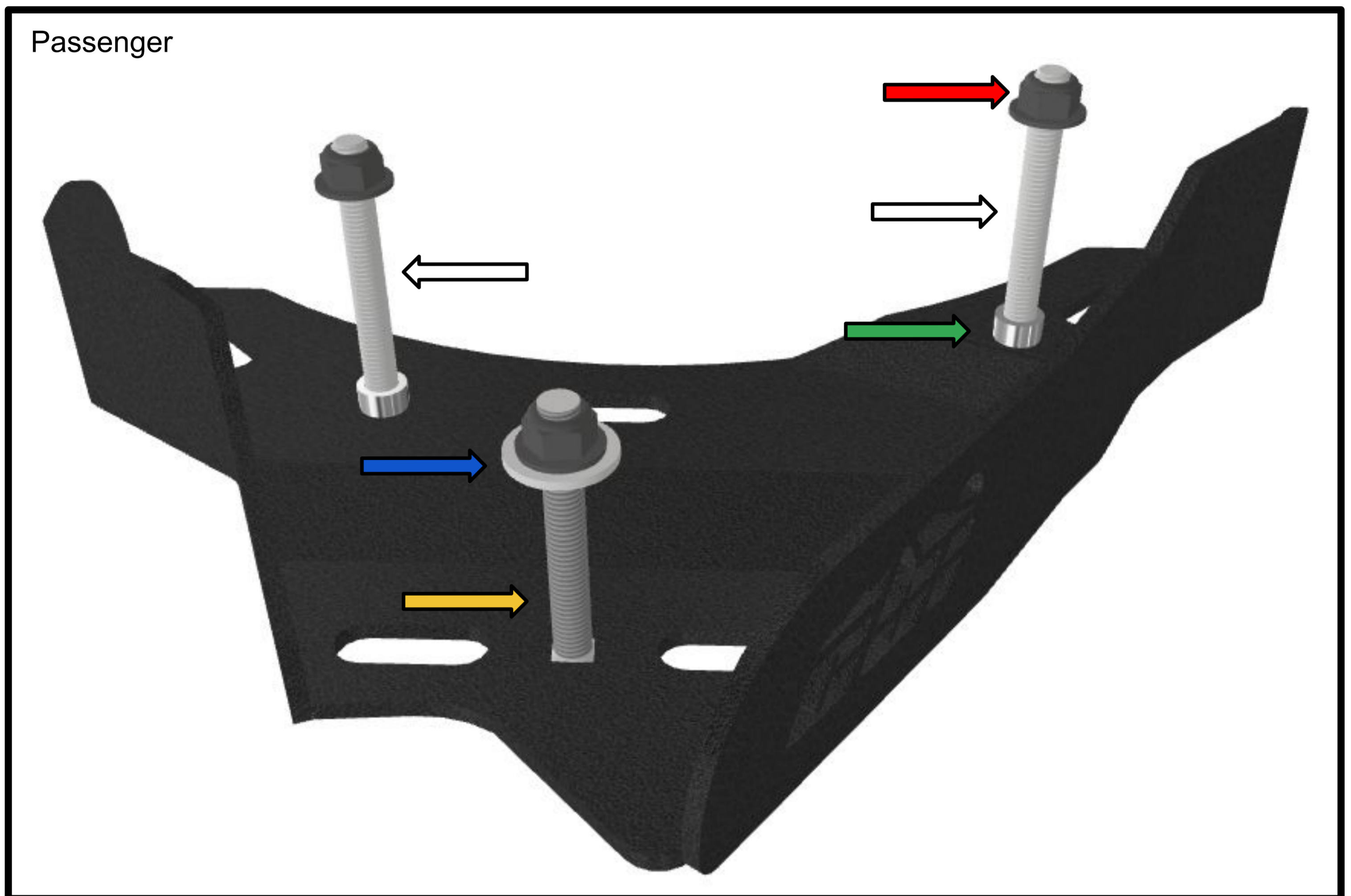

Installation - 5G 4Runner

Hardware indicated with colored arrows. Quantity listed pertains to each side.

- QTY (1) 3/8" x 3 1/2" carriage bolt (white)
- QTY (1) 3/8" x 4" carriage bolt (yellow)
- QTY (2) 3/8" nylon flange nut (red)
- QTY (2) 3/8" washer (blue)

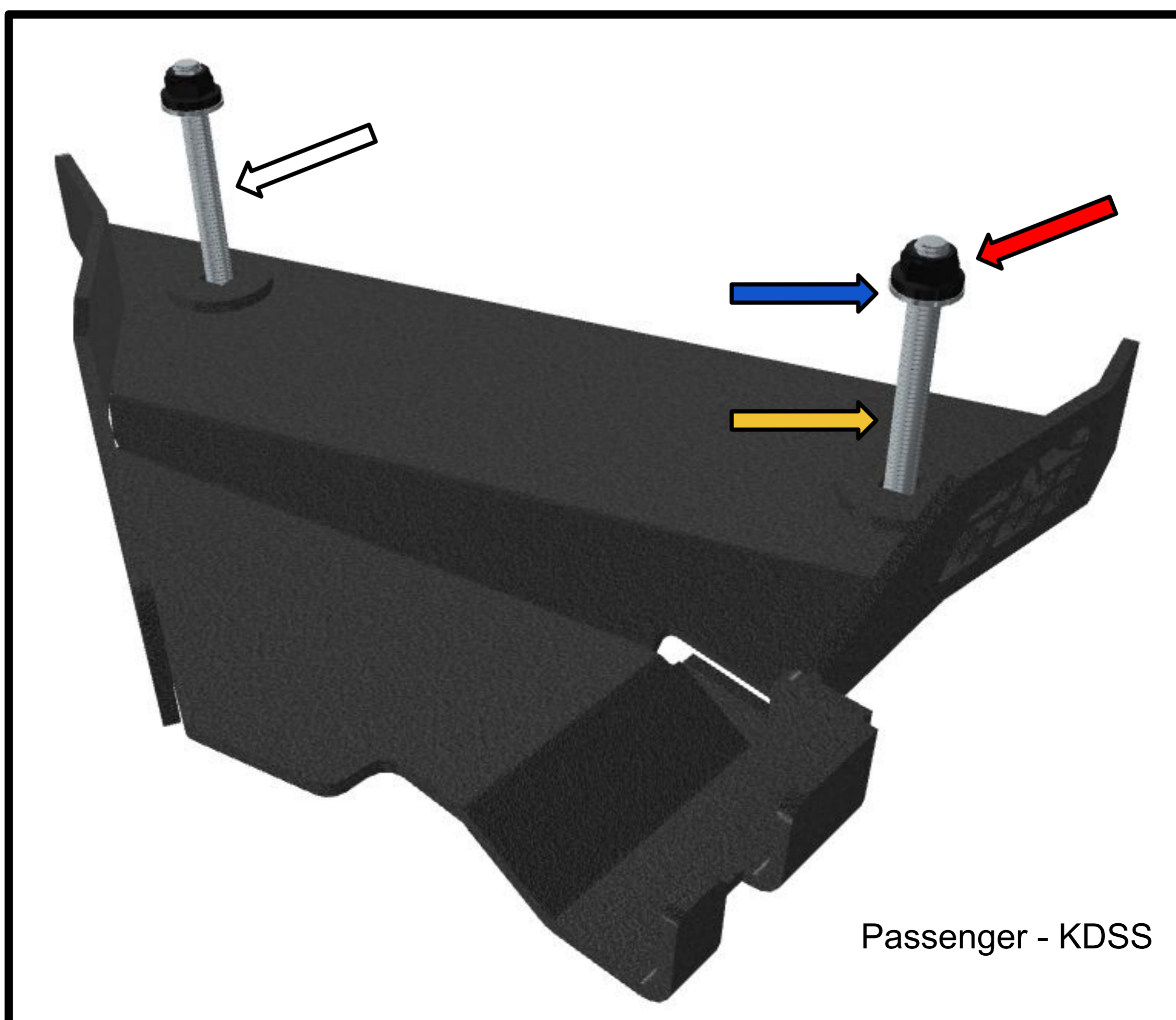
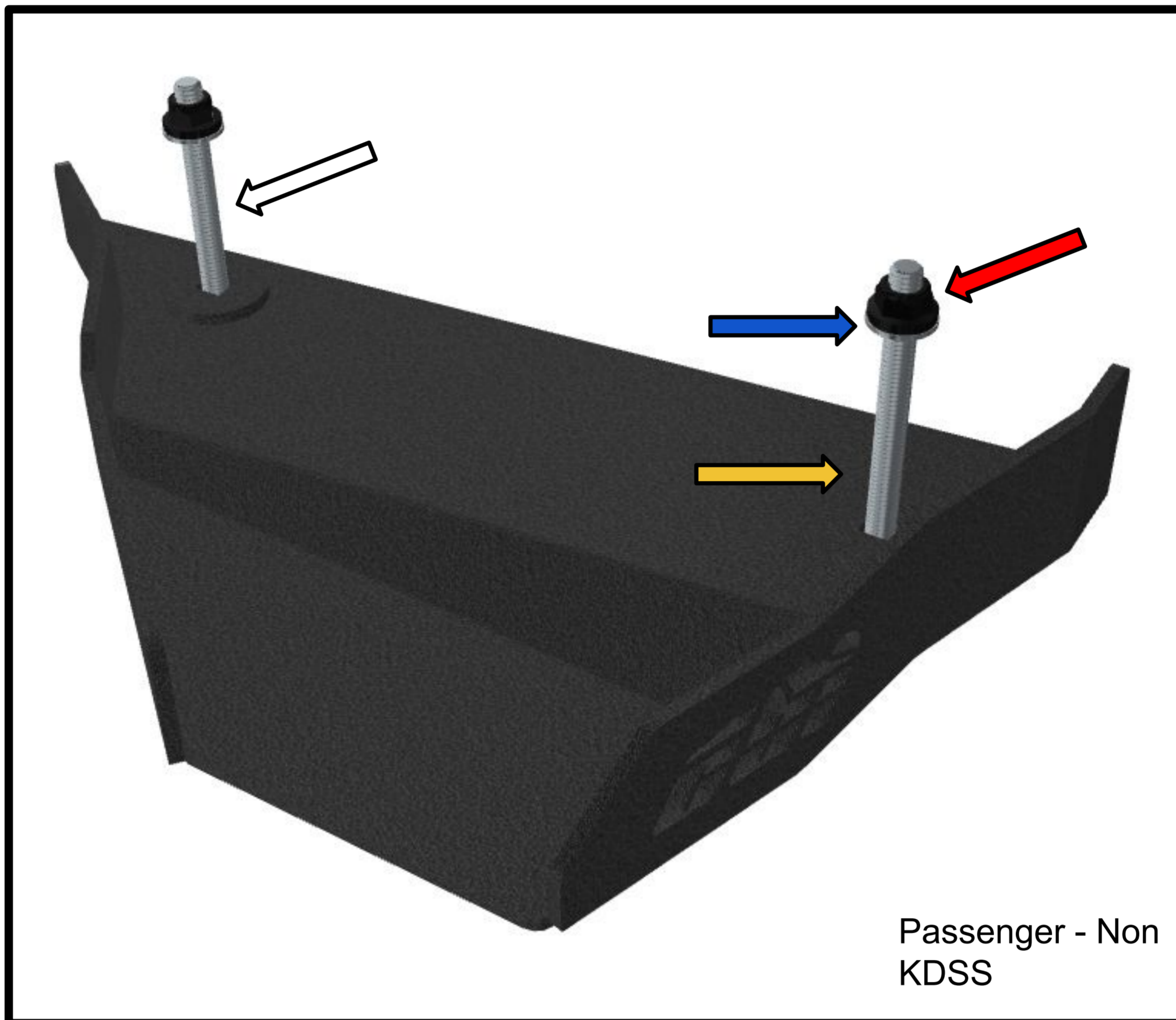

Installation - 6G 4Runner/LC250

Hardware indicated with colored arrows. Quantity listed pertains to each side.

- QTY (3) 3/8" x 4 1/2" carriage bolt (white)
- QTY (3) 3/8" nylon flange nut (red)
- QTY (3) 3/8" washer (blue)

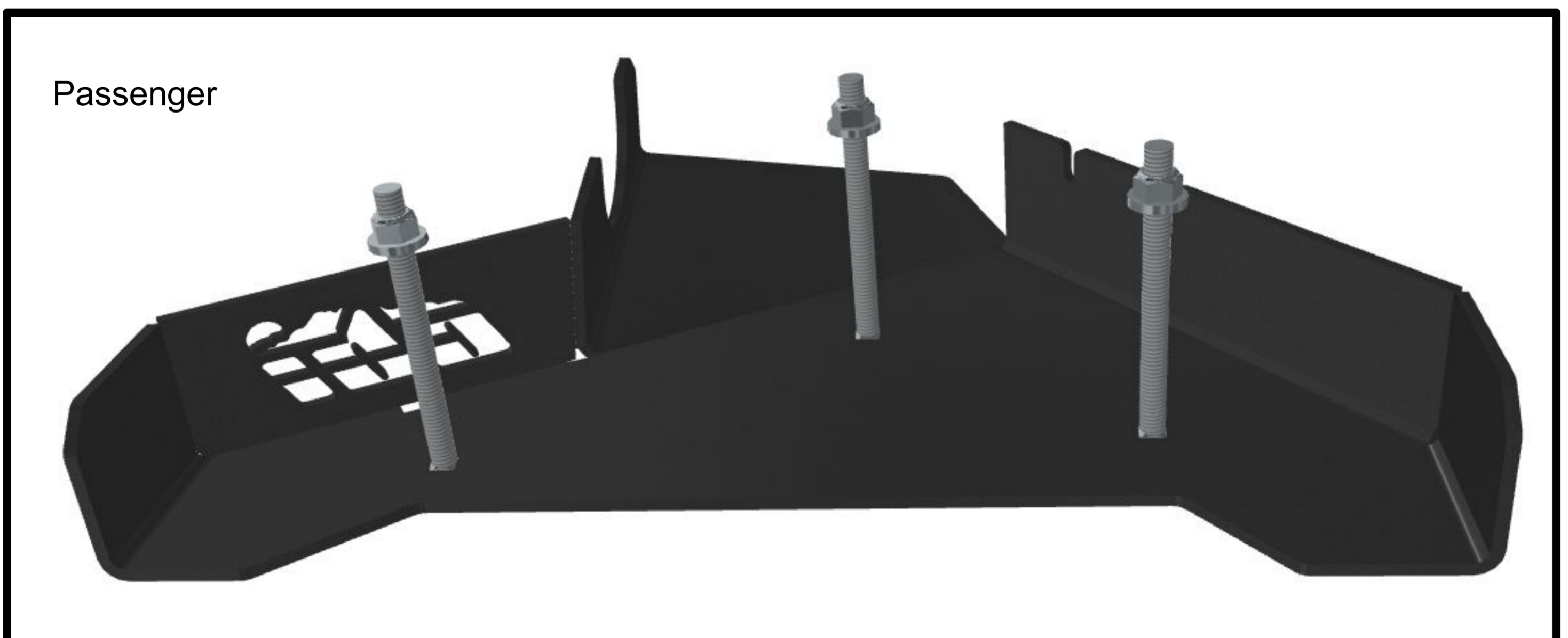
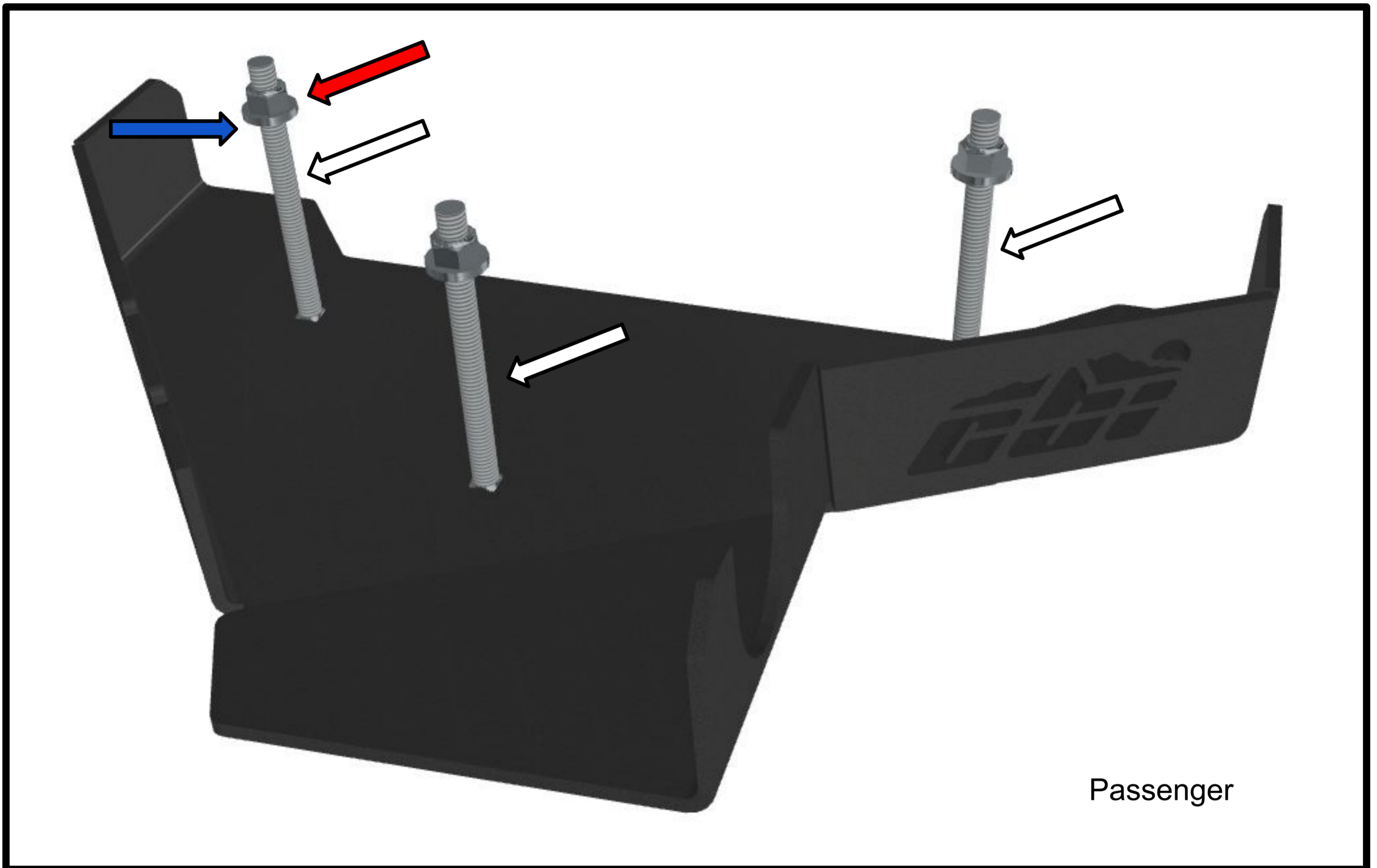

Installation - 2G/3G Tacoma

Hardware indicated with colored arrows. Quantity listed pertains to each side.

- QTY (1) 3/8" x 3" carriage bolt (white)
- QTY (1) 3/8" x 3 1/2" carriage bolt (yellow)
- QTY (1) 1/4" x 3" carriage bolt (orange)
- QTY (2) 3/8" square strut washer (blue)
- QTY (1) 1/4" x 1-1/2" fender washer (purple)
- QTY (2) 3/8" nylon flange nut (red)
- QTY (1) 1/4" nylon lock nut (black)
- QTY (1) Aluminum spacer (green)

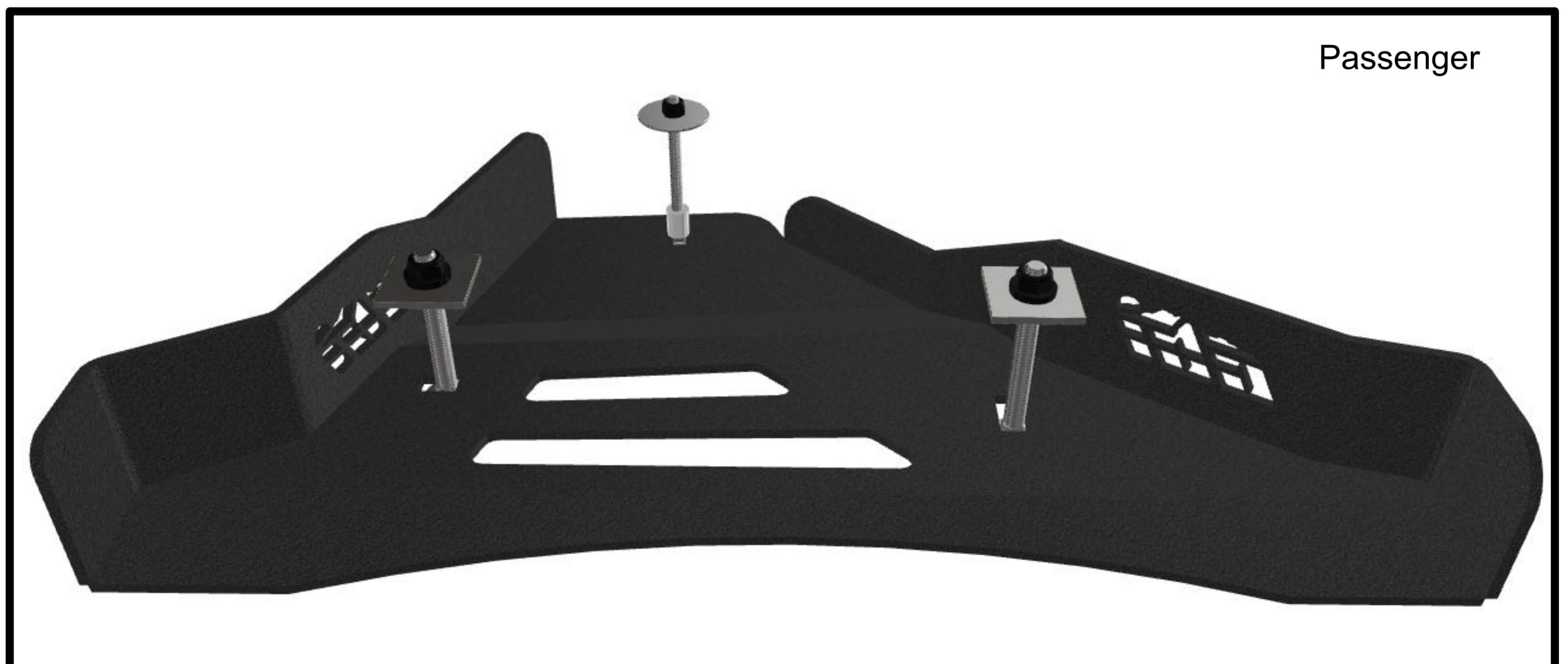
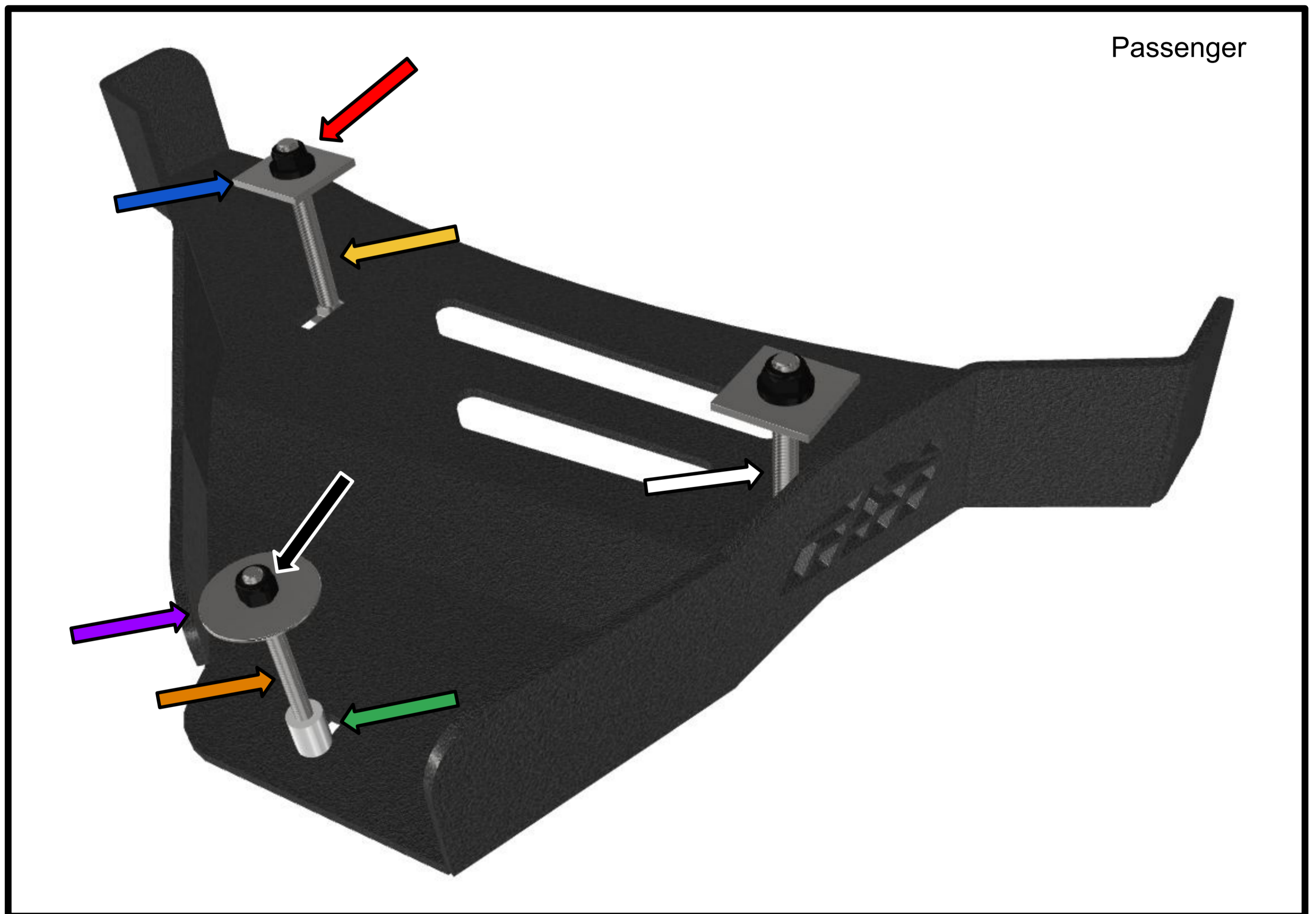

Installation - 4G Tacoma

Hardware indicated with colored arrows. Quantity listed pertains to each side.

- QTY (2) 3/8" x 4" carriage bolt (white)
- QTY (1) 3/8" x 4 1/2" carriage bolt (yellow)
- QTY (3) 3/8" nylon flange nut (red)
- QTY (3) 3/8" washer (blue)

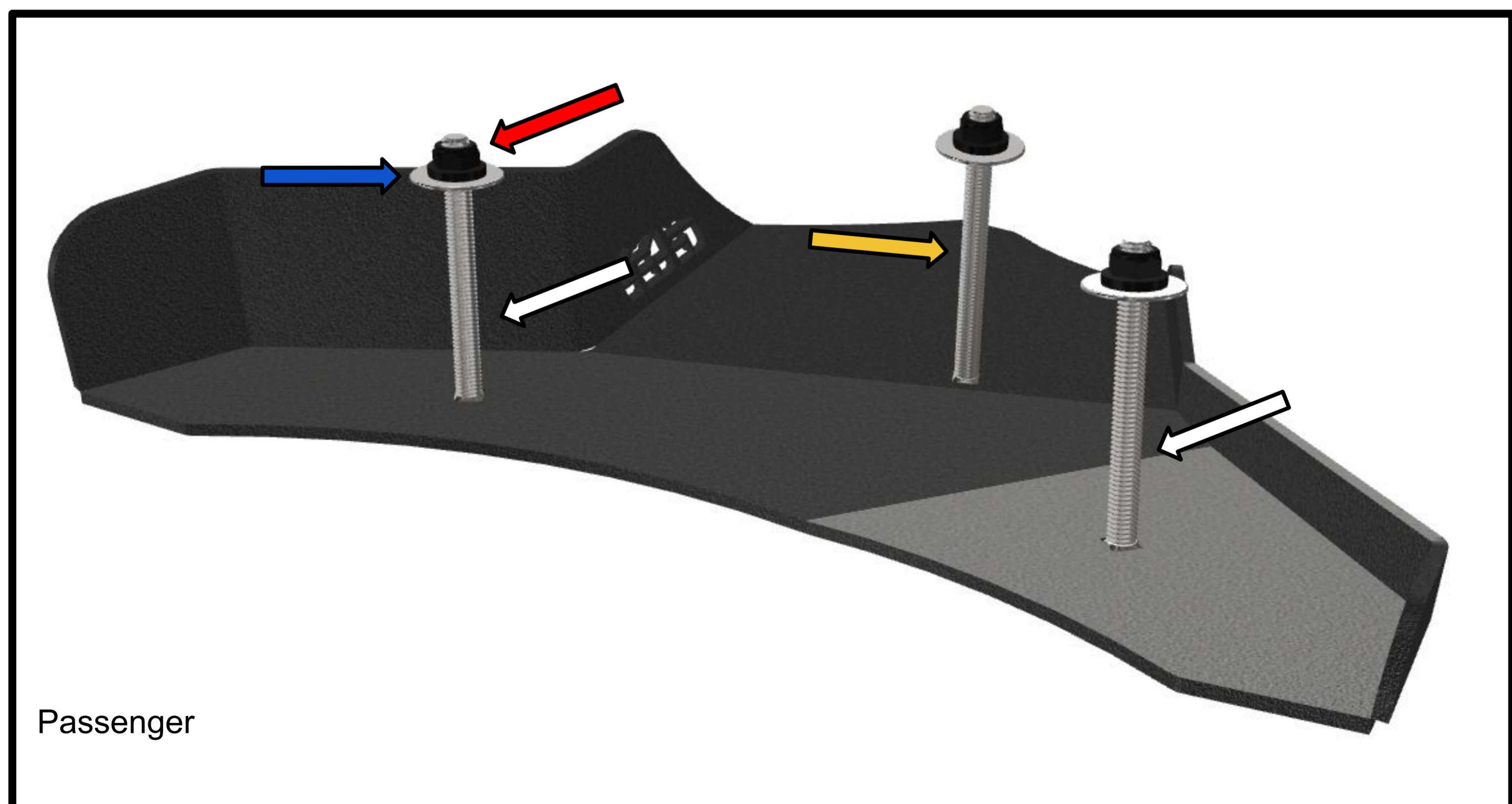
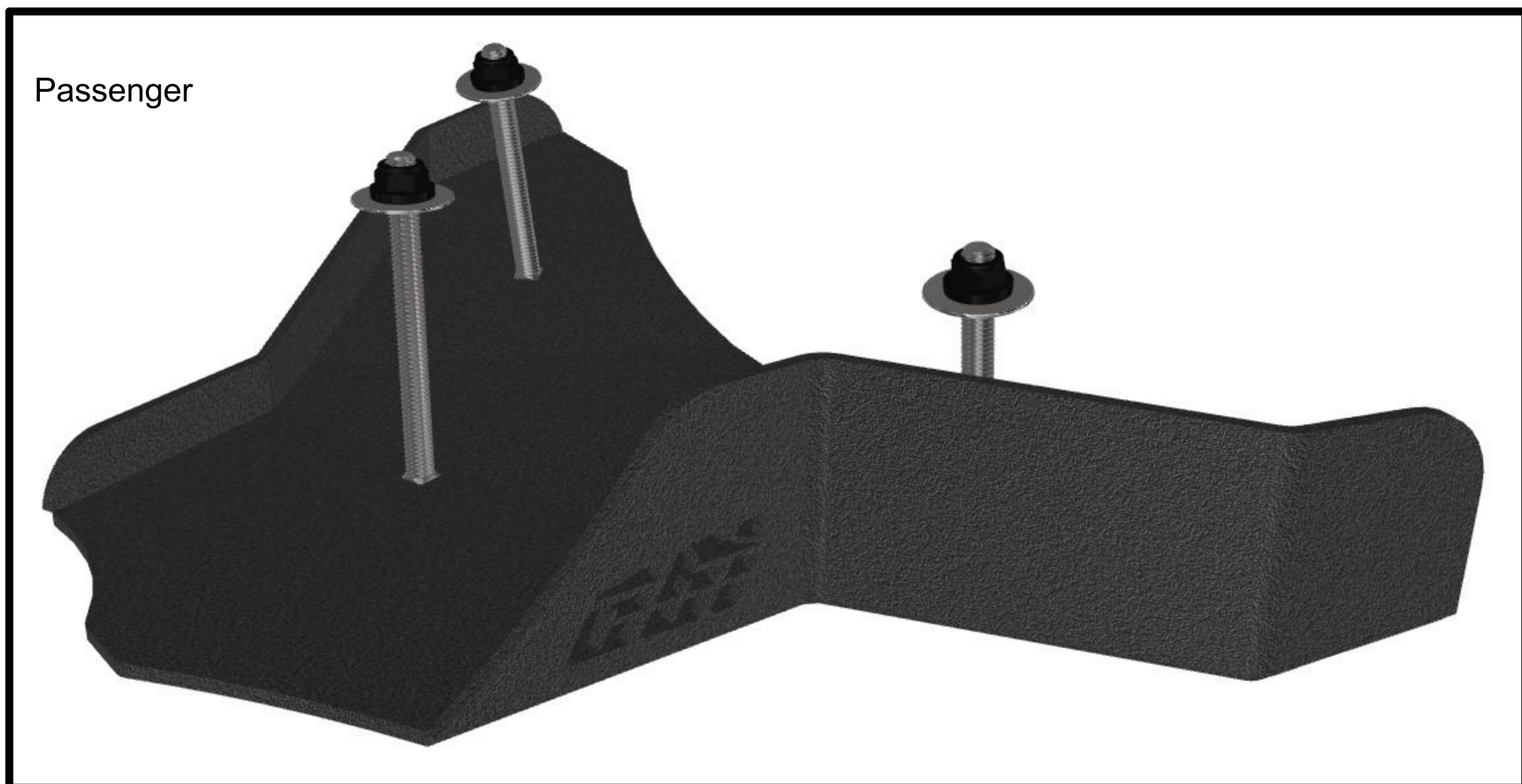

Installation - GX550

Hardware indicated with colored arrows. Quantity listed pertains to each side.

- QTY (3) 3/8" x 5" carriage bolt (white)
- QTY (3) 3/8" nylon flange nut (red)
- QTY (3) 3/8" washer (blue)

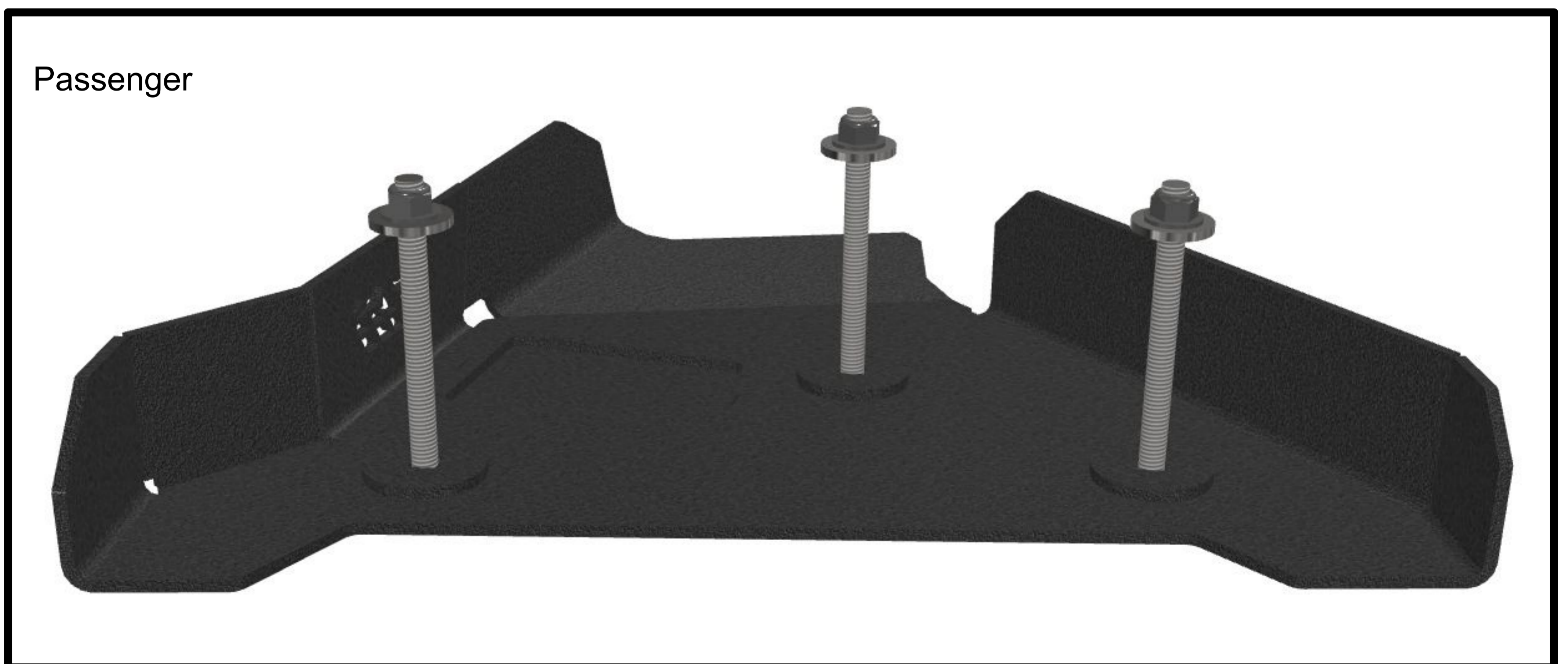
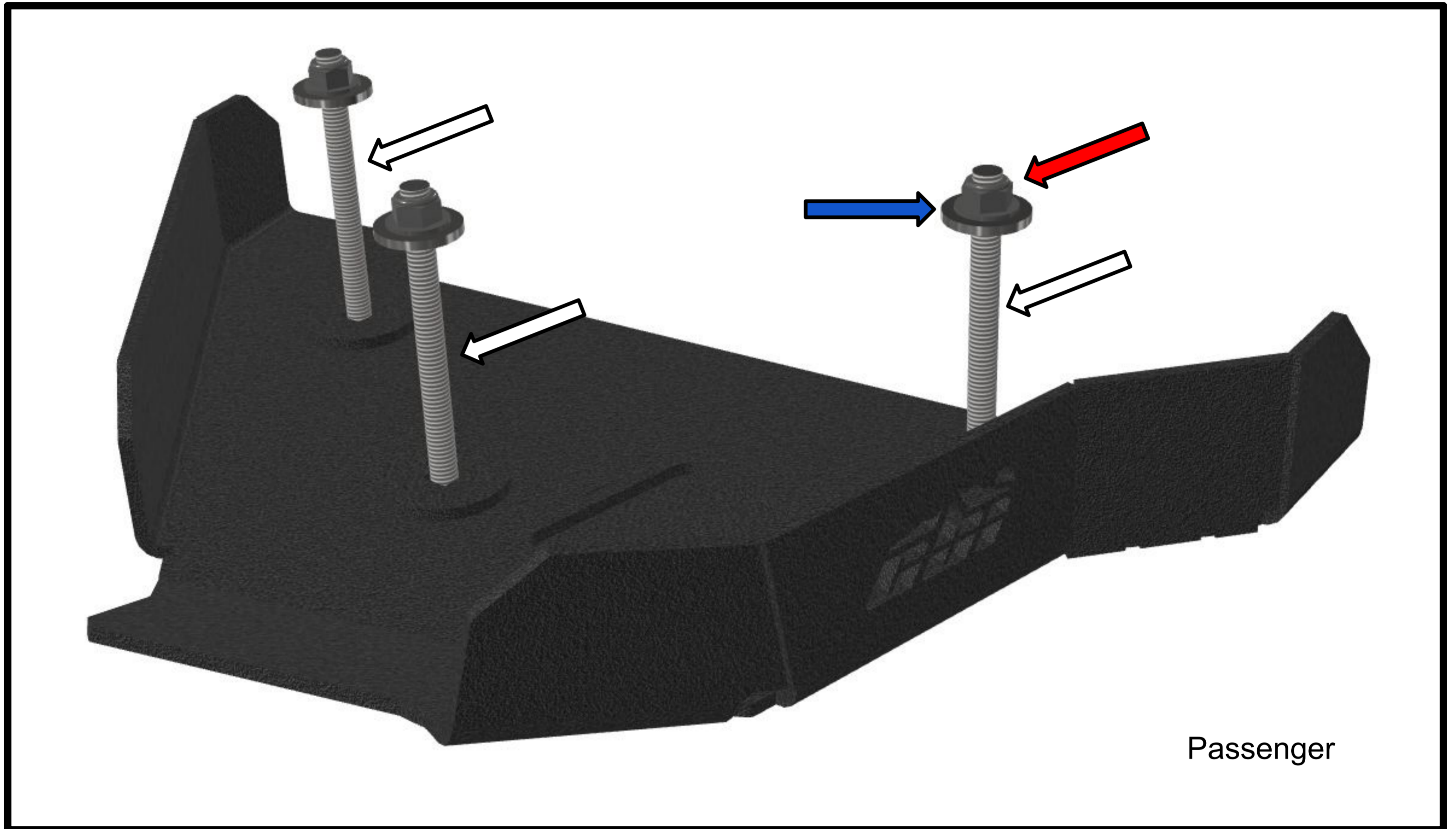

Installation is now complete!

For further information and assistance please call customer service: (866) 522-0697

WARRANTY

CBI Offroad Fab will warranty all CBI Offroad Fab manufactured parts for a LIFETIME of use. This limited Lifetime Warranty is effective for as long as the original retail purchaser owns the product. This warranty terminates when the original retail purchaser sells or otherwise transfers the product to any other person. Each manufactured product must be installed following CBI Offroad Fab's recommended fitment and installation procedures. Any customization or modification to the original product design, functionality, or use, either by said customer or by CBI Offroad Fab voids all warranty eligibility. It is the sole discretion of CBI Offroad Fab to determine warranty eligibility. Subject to the limitations and exclusions described in this warranty, CBI Offroad Fab will remedy defects in materials or workmanship by repairing or replacing, at its option, a defective product without charge for parts. In addition, CBI Offroad Fab may elect, at its option, not to repair or replace a defective product but rather issue to a purchaser a refund equal to the purchase price paid for the product or a credit to be used toward the purchase of a new CBI Offroad Fab product. No warranty is given for defects caused by normal wear and tear, cosmetic rust, scratches, accidents, unlawful vehicle operation, products used for racing or competition, or modification of, or any types of repair of, a CBI Offroad Fab manufactured product. The CBI Offroad Fab Warranty does not include the powder coated finish. No warranty is given for defects resulting from conditions beyond CBI Offroad Fab's control including, but not limited to, misuse, neglect, overloading, improperly maintained or failure to assemble, mount or use the product in accordance with CBI Offroad Fab's written instructions or guidelines included with the product or implied use made available to the purchaser.

DISCLAIMER OF LIABILITY REPAIR OR REPLACEMENT OF A DEFECTIVE PRODUCT OR THE ISSUANCE OF A REFUND OR CREDIT (AS DETERMINED BY PRINSU DESIGN STUDIO) IS A PURCHASER'S EXCLUSIVE REMEDY UNDER THIS WARRANTY. DAMAGE TO A PURCHASER'S VEHICLE, CARGO AND/OR TO ANY OTHER PERSON OR PROPERTY IS EXCLUDED. THIS WARRANTY IS EXPRESSLY MADE IN LIEU OF ANY AND ALL OTHER WARRANTIES, EXPRESS OR IMPLIED, INCLUDING THE WARRANTIES OF MERCHANTABILITY AND FITNESS FOR A PARTICULAR PURPOSE. PRINSU DESIGN STUDIO'S SOLE LIABILITY TO ANY PURCHASER IS LIMITED TO THE REMEDY SET FORTH ABOVE. IN NO EVENT WILL PRINSU DESIGN STUDIO BE LIABLE FOR ANY LOST PROFITS, LOST SALES, OR FOR ANY CONSEQUENTIAL, DIRECT, INDIRECT, INCIDENTAL, SPECIAL, EXEMPLARY, OR PUNITIVE DAMAGES OR FOR ANY OTHER DAMAGES OF ANY KIND OR NATURE



792 E Iona Rd.
Idaho Falls, ID 83274
cbioffroadfab.com
208.528.0664