



SHERPA
PREMIUM RACK SYSTEMS

MID HEIGHT 4 TOWER

BEDRACK SYSTEM INSTALL GUIDE

HARDWARE CHECKLIST

2

ACCESSORY
PANELS

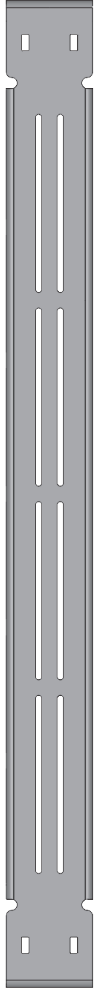

2

CROSSBARS
(BENT)

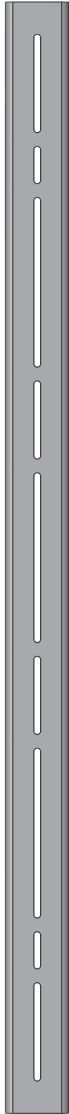

4

MID-HEIGHT TOWERS

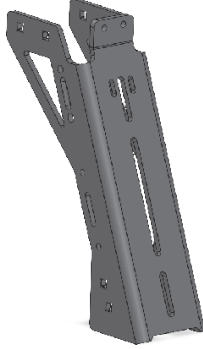

4

CHAIR
BRACKETS

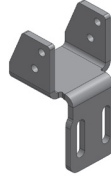

1

NAMEPLATE



HARDWARE CHECKLIST

48

5/16"-18x1"
CARRIAGE
BOLTS

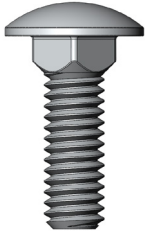

2

1/4"-20x1"
SB BOLTS



48

5/16"-18
NUTS

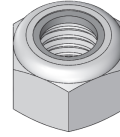

2

1/4"-20
NUTS

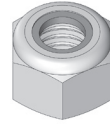

8

3/8" FLAT
WASHERS

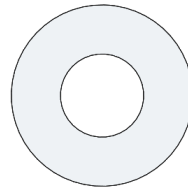

48

5/16" FLAT
WASHERS

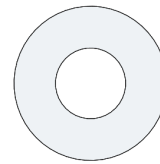

4

1/4" FLAT
WASHERS

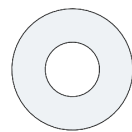

CLAMP MOUNT

TRACK MOUNT

8

3/8"-16x1"
HEX BOLTS



4

BEDNUTS

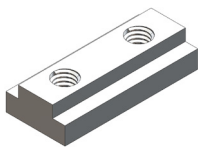

OR

8

3/8"-16x1-1/2"
HEX BOLTS



4

BED CLAMPS

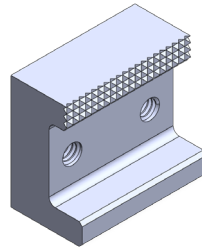

BEFORE YOU START

All images may differ slightly in appearance from actual product.

USING
TNUTS

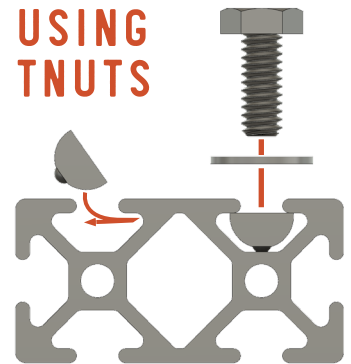

TOWER ASSEMBLY

01 CHAIR ASSEMBLY

Required Components:

- 2 Tower
- 2 Chair Bracket
- 8 5/16"-18 Carriage Bolt
- 8 5/16" Washer
- 8 5/16"-18 Nut

Fasten each chair bracket to a tower using the supplied carriage bolts, washers, and nylock nuts. Leave hardware loose for later adjustment.

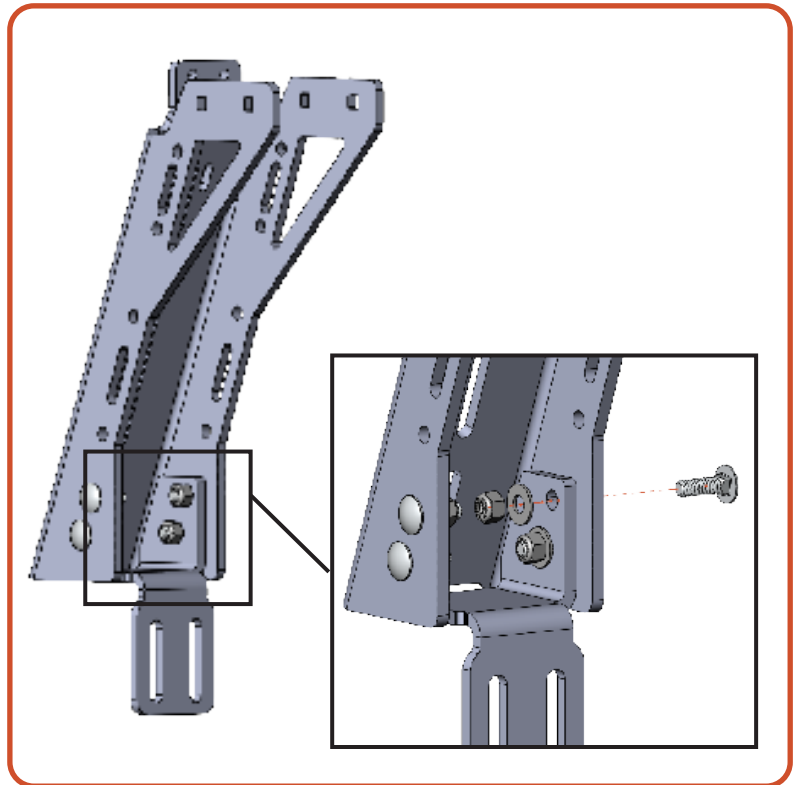

02 TOWER ASSEMBLY

Required Components:

- 1 Crossbar
- 2 Chair Assemble
- 4 5/16"-18 Carriage Bolt
- 4 5/16" Washer
- 4 5/16"-18 Nut

Secure the crossbar to the 2 towers, leaving the hardware loose so that it can be adjusted during a later step.

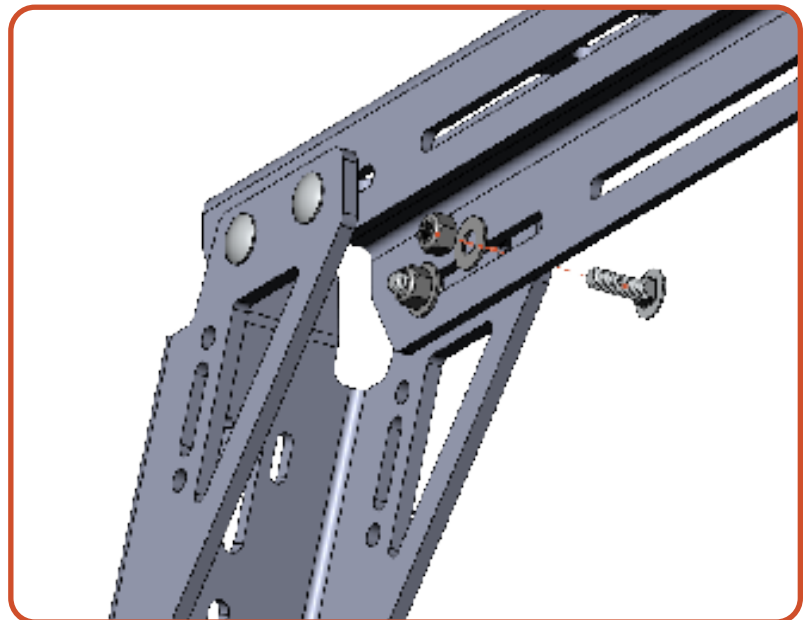

03 TOWER ASSEMBLY

Repeat steps 1 and 2 for all tower assemblies



TRACK STYLE INSTALL

01 BED NUTS

For vehicles with clamp style mounting, use the following page.

Required Components:

- 2 Bed Nut
per tower assembly

Insert the supplied bed nuts to the rail. Space the bed nuts out along the rail to match accessory panel spacing. **Repeat for all tower assemblies.**



02 TOWERS

Required Components:

- 1 Tower Assembly
- 4 3/8"-16x1" Hex Bolt
per tower assembly
- 4 3/8" Flat Washer
per tower assembly

Fasten each tower to the factory bed rail by bolting through the chair brackets into the bed nut using the supplied 3/8"-16 x 1" hex bolts and 3/8" washers. **Repeat for all tower assemblies.** Leave the bolts loose for later adjustment.

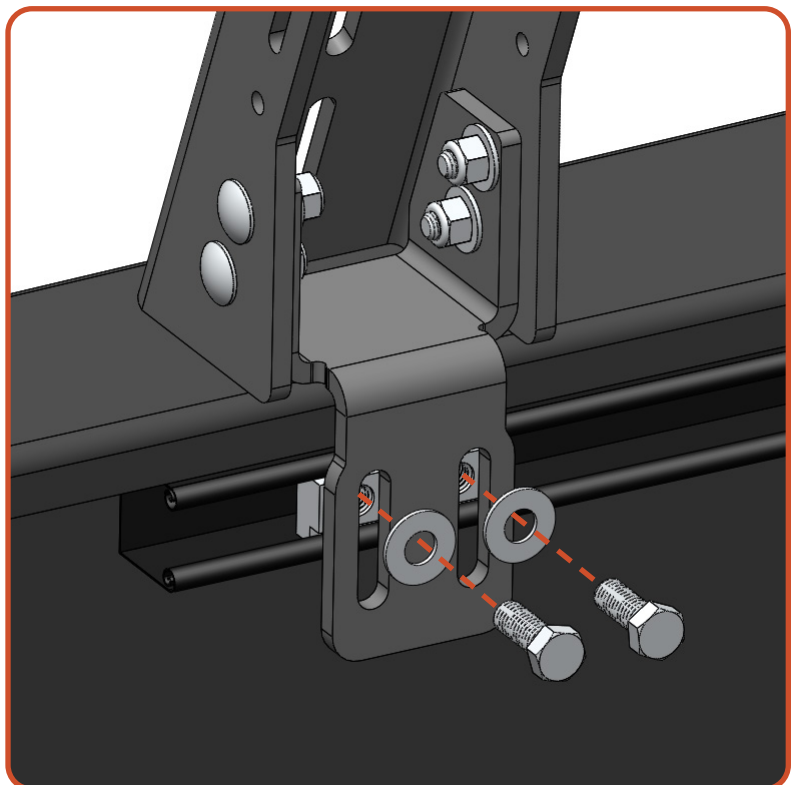

CLAMP STYLE INSTALL

01 TOWERS

For vehicles with track style mounting, use the previous page.

Required Components:

- 2** C-Clamp
- per tower assembly**
- 4** 3/8"-16x1-1/2" Bolt
- per tower assembly**
- 4** 3/8" Flat Washer
- per tower assembly**

Clamp a tower assembly to the bedside using the supplied bolts, washers, and C-Clamps. Leave hardware loose for later adjustment.

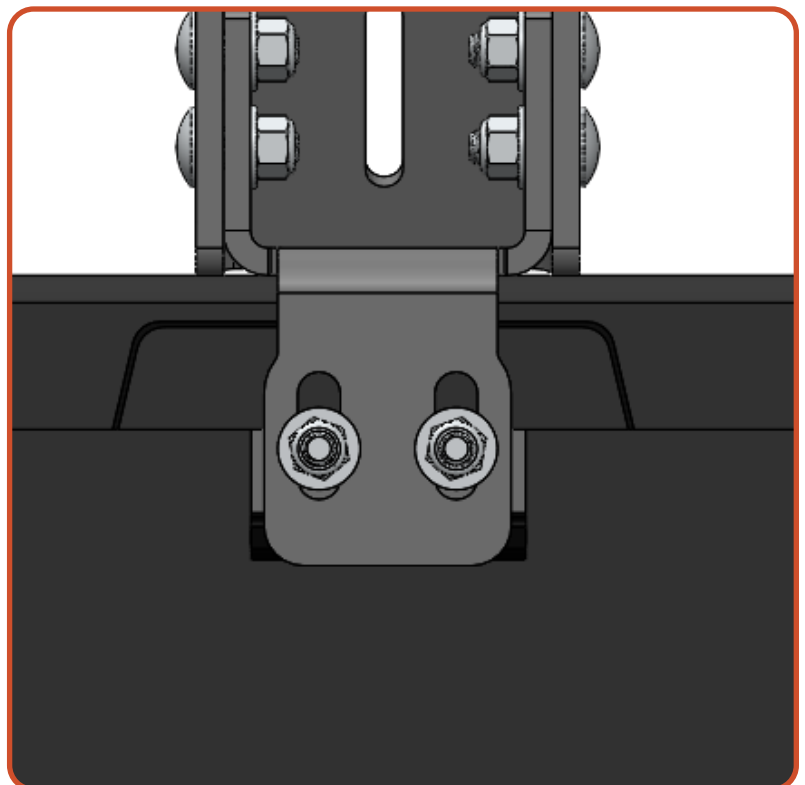
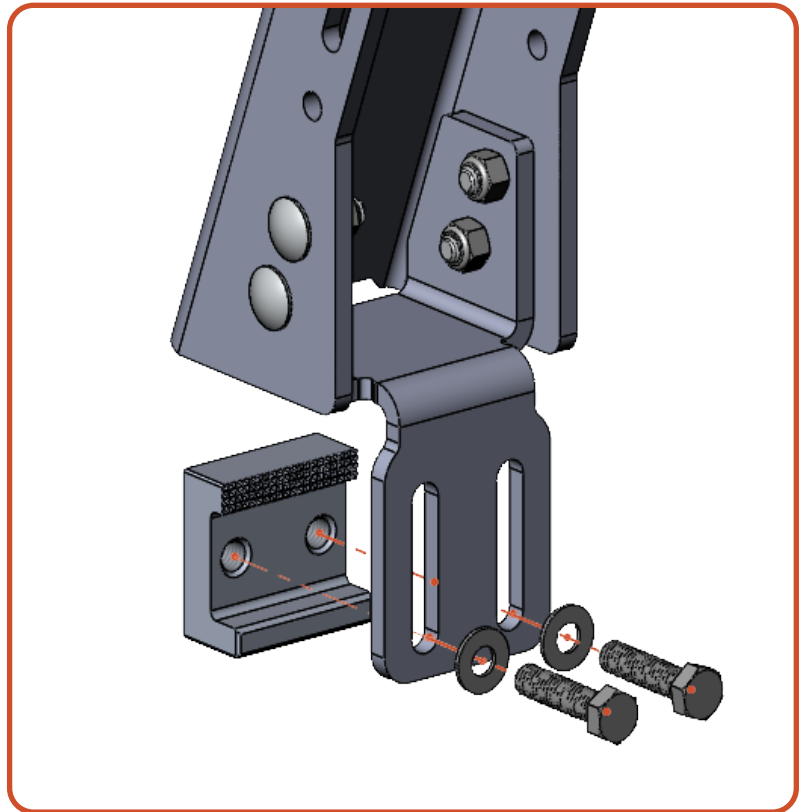

ACCESSORY PANELS

01 TOWER PLACEMENT

Measure the distance between the mounting slots to set the towers at the proper length along the bed rails. If a roof rack is present, ensure a minimum distance of 1-1/2" between PAK sideplate and roof rack sideplate.

Below are examples showing the measurements needed to correctly space the towers for accessory panels.

Leave hardware loose until later step.



02 ACCESSORY PANELS

Required Components:

- 2 Accessory Panels
- 16 5/16"-18 Carriage Bolt
- 16 5/16" Washer
- 16 5/16"-18 Nut

Attach accessory panels to towers, using the carriage bolts, nuts, and washers. Once all hardware is in place, hold the **corner** of the accessory panel tight onto the **corner** of the tower and torque to 5/16"-18 nuts to 11 ft-lbs.

Repeat for all towers.

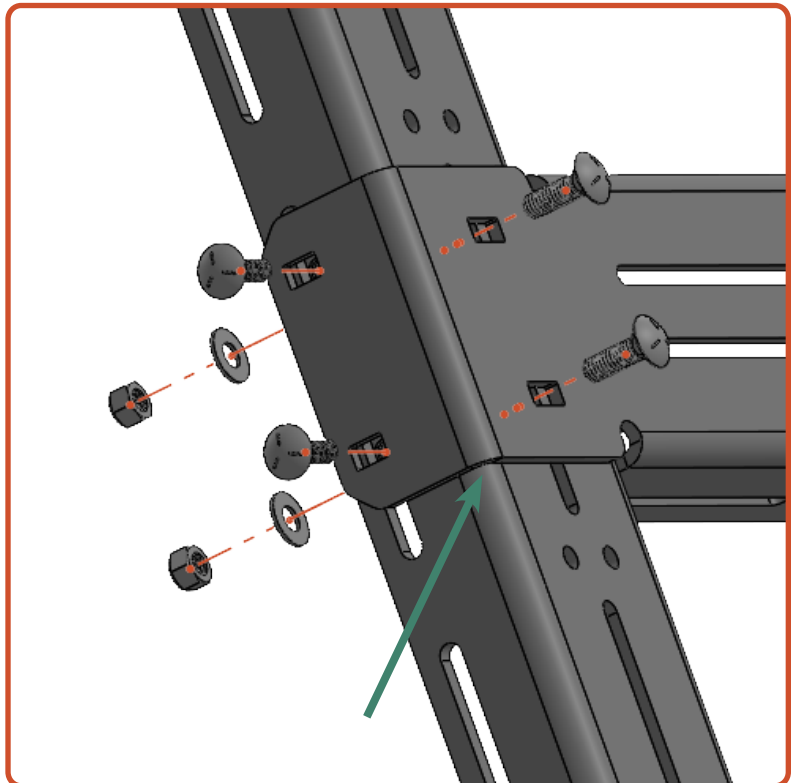

ADJUSTMENT

01 ADJUST AND TORQUE

First, adjust towers and bent/main crossbars to ensure crossbar are level, centered, and sideplates are aligned with cab. Once leveled and aligned, torque upper 5/16"-18 nuts to 11 ft-lb. Repeat for all crossbar and tower assembly.

Next, ensure chair bracket is flush with bed. Torque lower 5/16"-18 nuts to 11 ft-lb. Repeat for each tower and chair bracket assembly.

Lastly, torque track/clamp 3/8" hex bolts to 10 ft-lb. Repeat for each chair bracket.

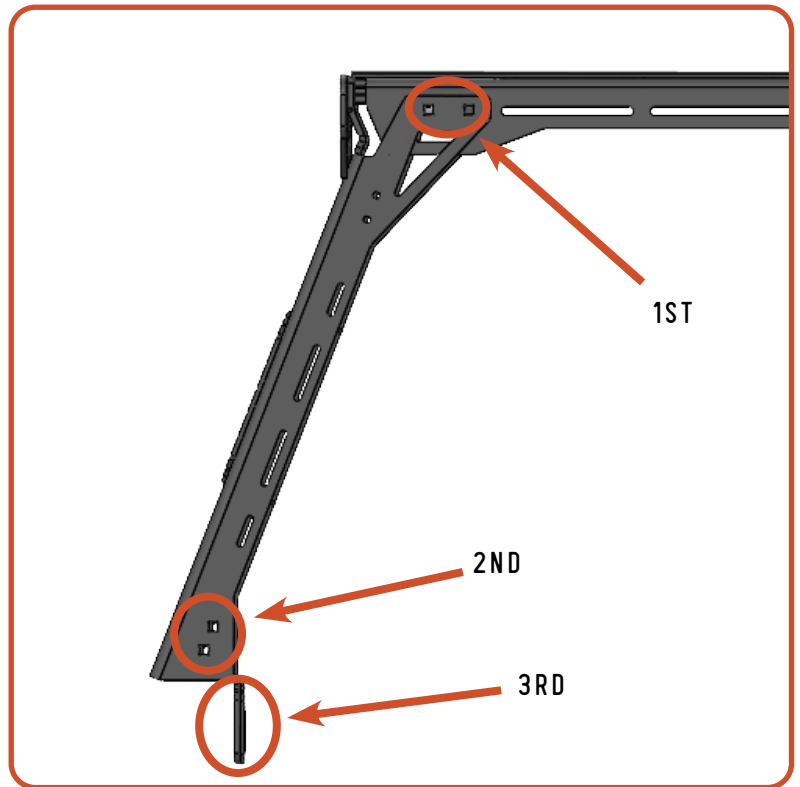

04 SHERPA NAME PLATE

Required Components:

- 2 1/4"-20 x 3/4" Carriage Bolt
- 2 1/4"-20 Nylock Nut
- 2 1/4" Flat Washer
- 1 Sherpa Name Plate
- 1 Name Plate Backer

Using the 1/4"-20 x 3/4" carriage bolts, 1/4" flat washers, and nylock nuts attach the name plate and name plate backer to the rear bed rack cross bar.



NOW GET OUT THERE AND
EXPLORE.

WELCOME TO THE SHERPA FAMILY!
MAKE SURE TO FOLLOW US ON YOUR SOCIALS AND TAG US IN YOUR ADVENTURES.

All products built and designed by Sherpa Equipment Company are intended for off-road use and should be assembled, installed, and used according to Sherpa Equipment Company's recommendations. Sherpa Equipment Company's products should be used safely with good judgment towards others and surroundings.

By installing Sherpa Equipment Company's products on your vehicle you assume all liability. Sherpa Equipment Company will not be held liable for damages or loss associated with the installation or use of its products. It is recommended that you inspect your roof rack within the first 100 miles of installation and every 500 miles after.