



INSTALLATION GUIDE

2024-UP | TOYOTA LAND CRUISER

[ROOF RACK SOLID VALANCE]

1624-70100



TOOLS REQUIRED

- 12mm, 13mm, 7/16, 9/16 Wrenches
- 7/16, 9/16, 12mm, 13mm Sockets
- 5/32, 7/32 Hex
- Plastic Pry Tool
- Razor Blade

SKILL LEVEL

- Medium

TIME REQUIRED

- Approximately 3 Hours

⚠️ WARNINGS/CAUTIONS BEFORE STARTING INSTALLATION ⚠️

-BEFORE YOU INSTALL THIS KIT-

Read and understand all instructions, warnings, cautions, & notes contained in this installation instruction guide. Consult your vehicle owner's manual for proper disconnection of electrical and lifting of vehicle if required for installation of this product.

This install may require some technical skills and knowledge of basic mechanical work. If you do not feel that you are capable of performing this install please take this product to a trained professional.

After reading this guide please contact us with any questions or concerns before installing product.

Customer Service: 1-605-721-2911
C4 Fabrication is **not** responsible for any bodily injury or harm to you or your vehicle as a result of an improper install.

Proper installation of this kit required knowledge of the factory recommended procedures for removal and installation of original equipment components.

We recommend that the factory shop manual and any special tools needed to service your vehicle be on hand during the installation. Installation of this kit without proper knowledge of the factory recommended procedures may affect the performance of these components and the safety of the vehicle.

Inspect all contents of this package to make sure product is not damaged and all installation hardware has been included. If parts are missing from kit, please be prepared to provide the following information:

1. Name of purchase location
2. Bar Code on side of box
3. Date above bar code
4. Date inside box cover

ALWAYS WEAR EYE PROTECTION WHEN OPERATING POWER TOOLS

[A.]

36x

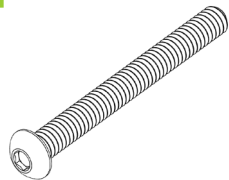

1/4-20 X 2" BUTTON HEAD BOLT
5/32 ALLEN

[B.]

18x

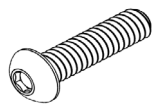

1/4-20 X 1" BUTTON HEAD BOLT
5/32 ALLEN

[C.]

24x



1/4-20 X 1/2" BUTTON HEAD BOLT
5/32 ALLEN

[C1.]

72x



M6 FLAT WASHER

[C2.]

18x



1/4" FLAT WASHER

[C3.]

18x

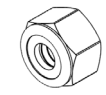

1/4-20" NYLON LOCK NUT
7/16 WRENCH

[D.]

20x

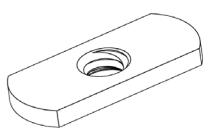

1/4-20 T-NUT

[E.]

4x

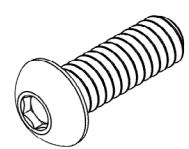

3/8-16 X 1" BUTTON HEAD BOLT
7/32 ALLEN

[E1.]

4x

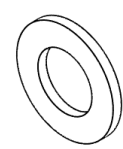

3/8" FLAT WASHER

[E2.]

4x



3/8-16 NYLON JAM LOCKNUT
9/16 WRENCH

[F.]

36x

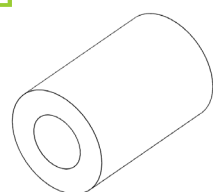

1/4' X 1' SPACER

[G.]
12x



MUS0008

[H.]
1x



EDGE TRIM WITH GASKET

INSTALL

- A: 1/4-20 X 2" BUTTON HEAD BOLT (18X)
- C1: M6 FLAT WASHER (19X)
- C2: 1/4" FLAT WASHER (1X)
- C3: 1/4-20" NYLON LOCK NUT (1X)
- F: 1/4" - 1" SPACER (18X)

STEP 1

Using a 5/32 allen and a 7/16 wrench install the provided hardware (A, C1, C2, C3, F), to assemble the side panels to the rails as shown below. (Leave hardware loose at this time).

TECH TIP: Apply blue loctite to all hardware.

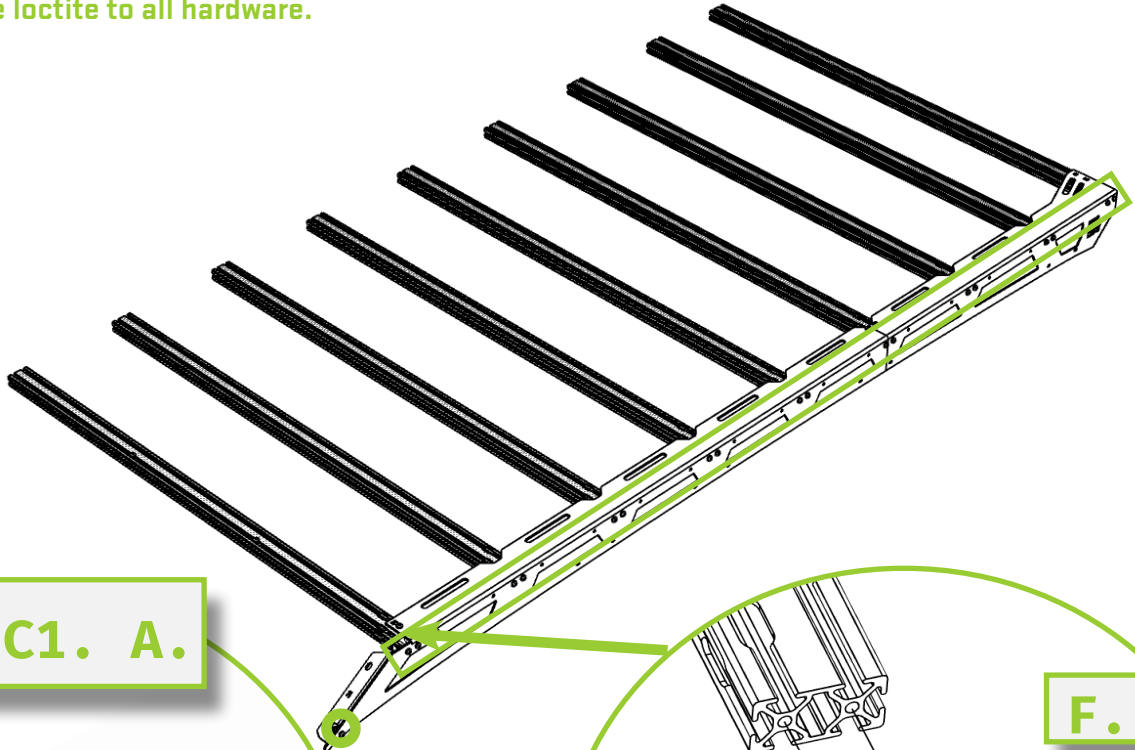

C3. C2. | C1. A.

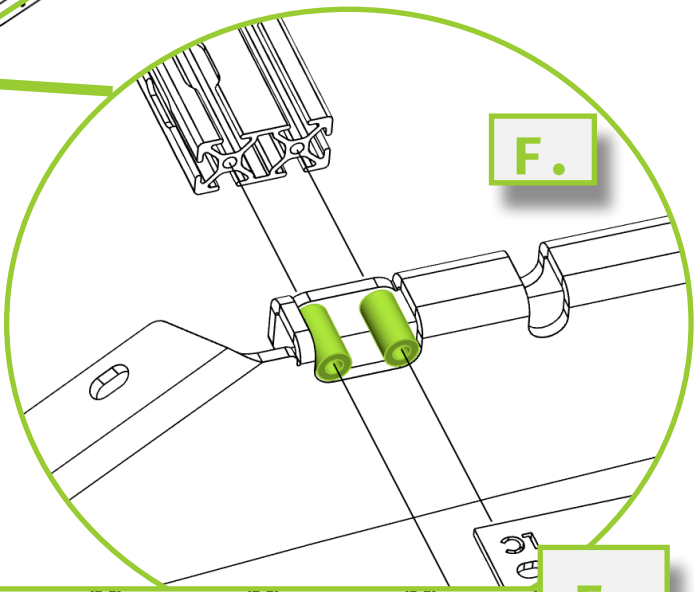
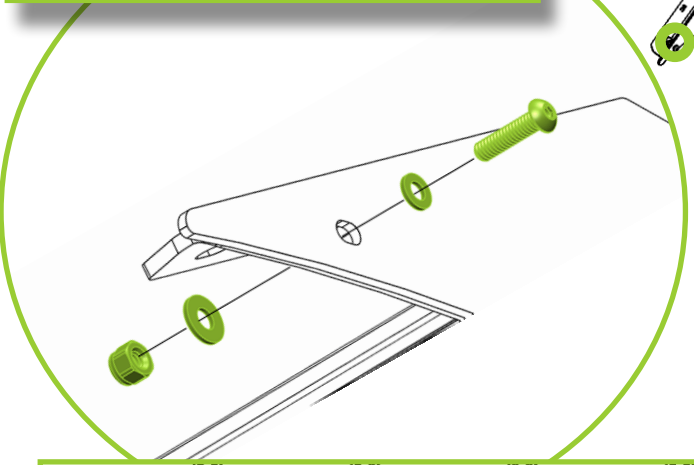

F.

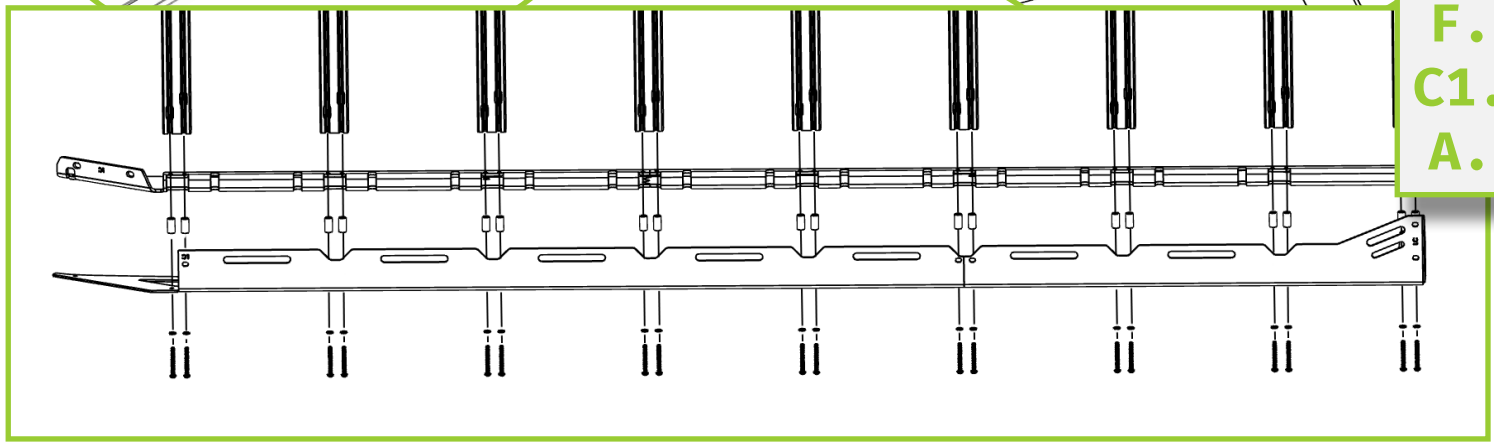

F.
C1.
A.

STEP 2

Install **D** T-nuts into the locations indicated below.

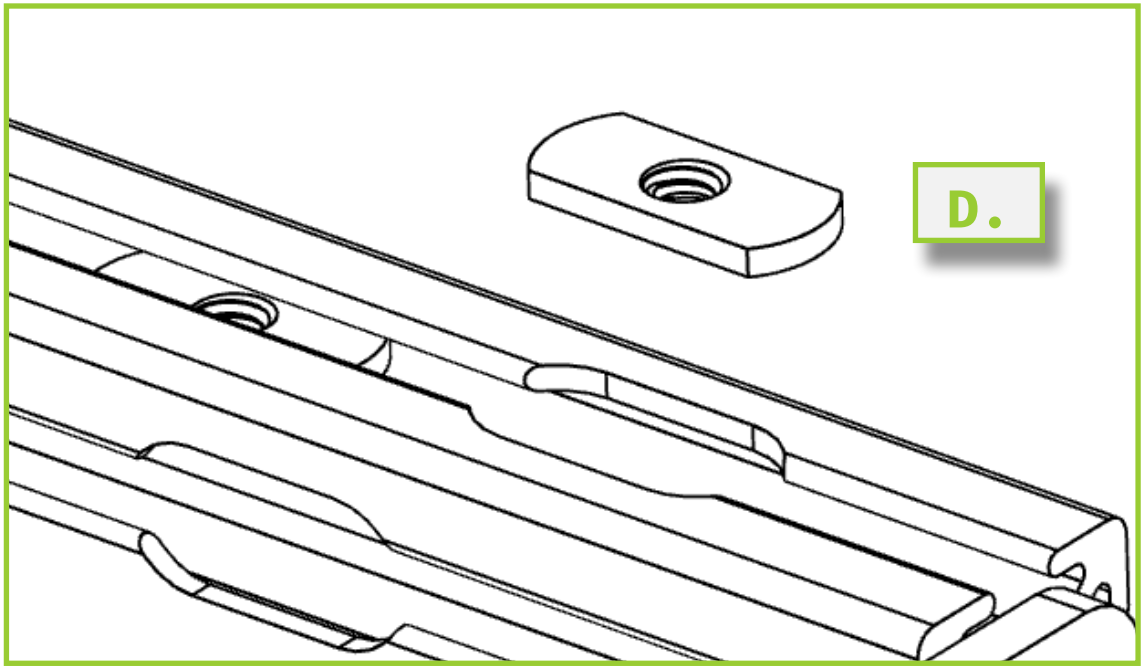
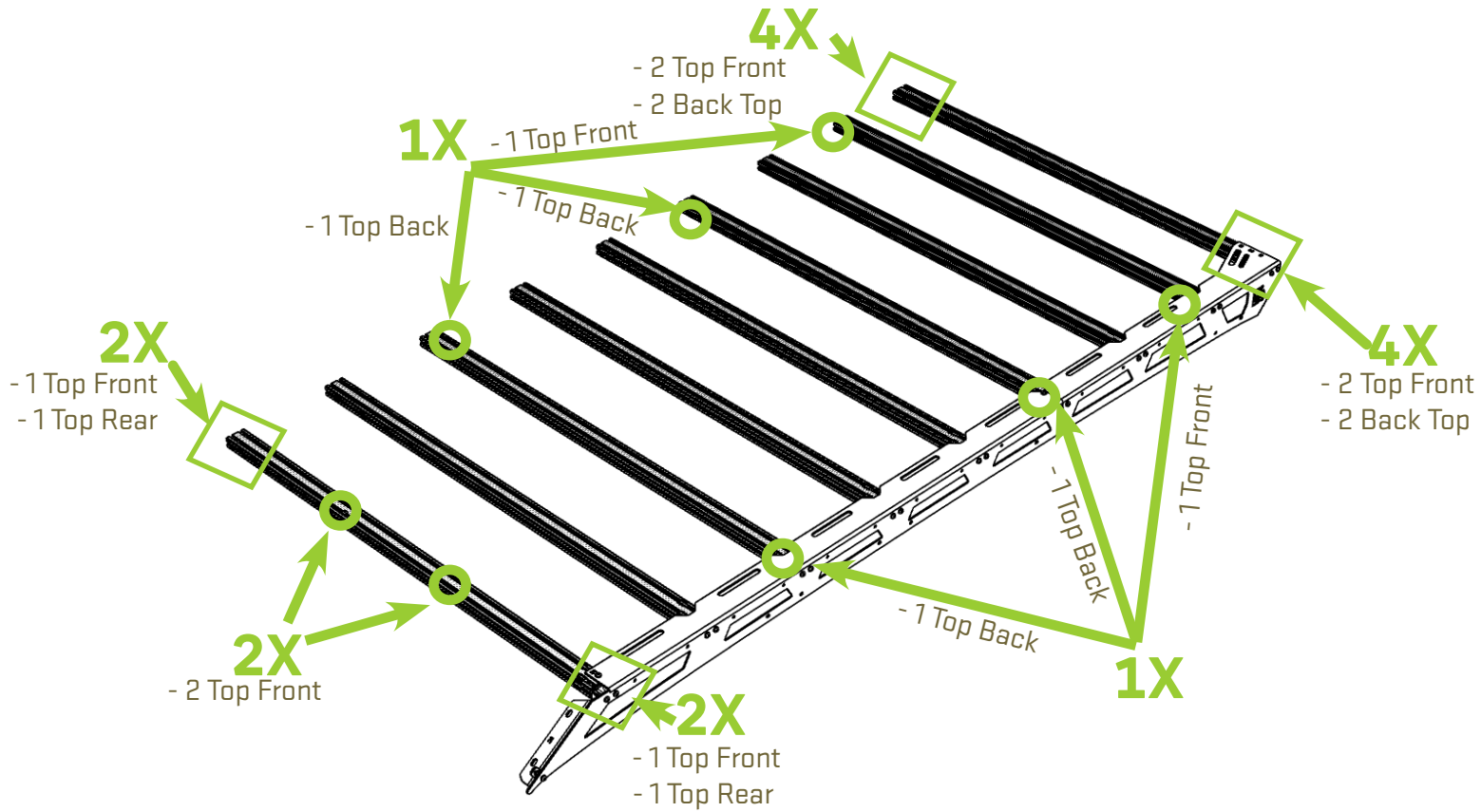

- A: 1/4-20 X 2" BUTTON HEAD BOLT (18X)
- C1: M6 FLAT WASHER (19X)
- C2: 1/4" FLAT WASHER (1X)
- C3: 1/4-20" NYLON LOCK NUT (1X)
- F: 1/4" - 1" SPACER (18X)

STEP 3

Using a 5/32 allen and a 7/16 wrench install the provided hardware (A, C, C1, C2, F), to assemble the side panels to the rails as shown below. (Leave hardware loose at this time).

TECH TIP: Apply blue loctite to all hardware.

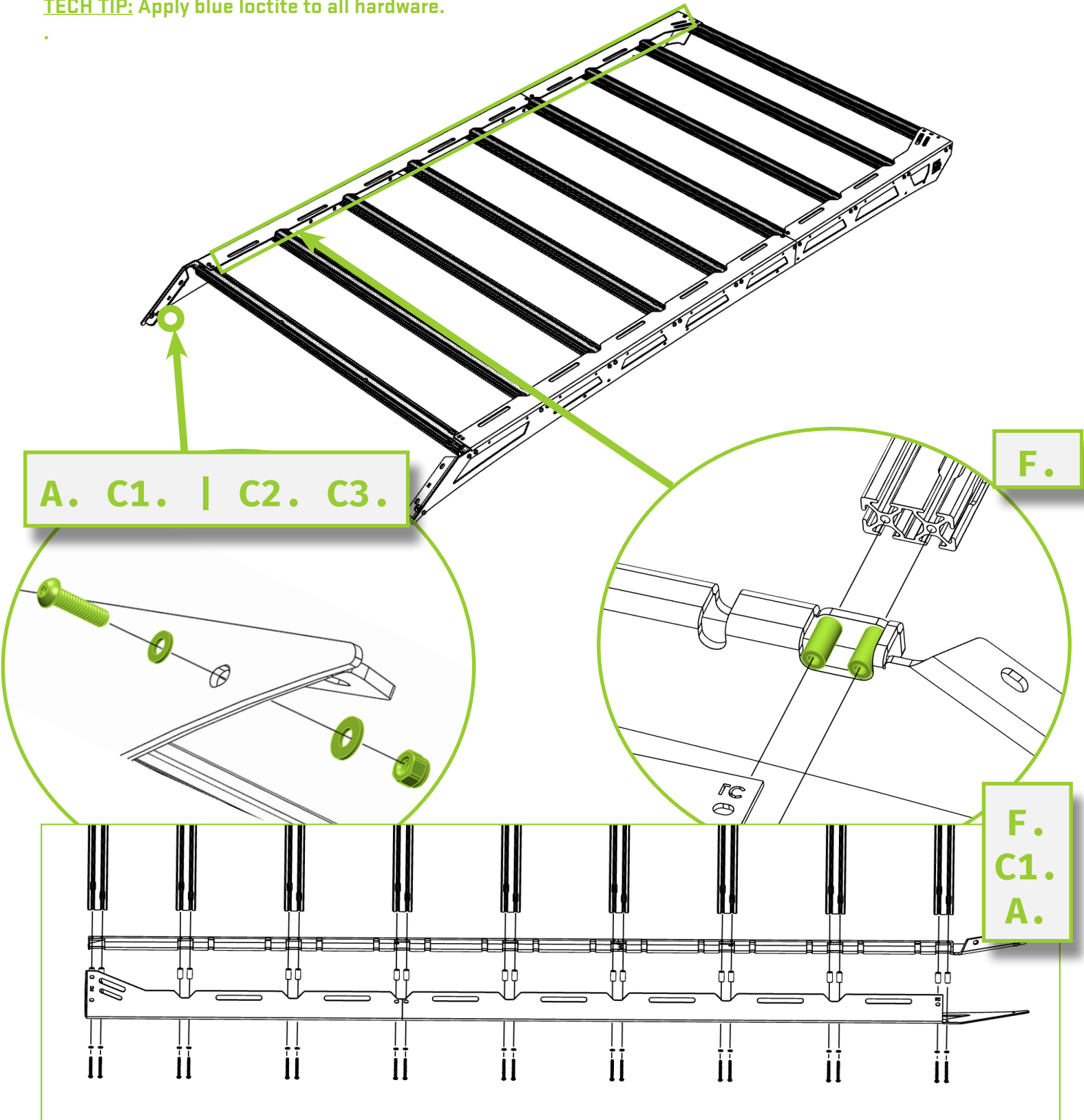

- E: 3/8-16 X 1" BUTTON HEAD BOLT (4X)
- E1: 3/8" FLAT WASHER (4X)
- E2: 3/8-16" NYLON LOCK NUT (4X)
- C: 1/4-20 X 1/2" BUTTON HEAD BOLT (6X)
- C1: M6 FLAT WASHER (6X)

STEP 4

Starting from the front corner, align the valence for best fitment. Then use the previously specified tools to tighten each bolt (C, C1, E, E1, E2) to secure the entire roof rack assembly.

TECH TIP: Ensure that blue loctite is applied to all non-locking hardware.

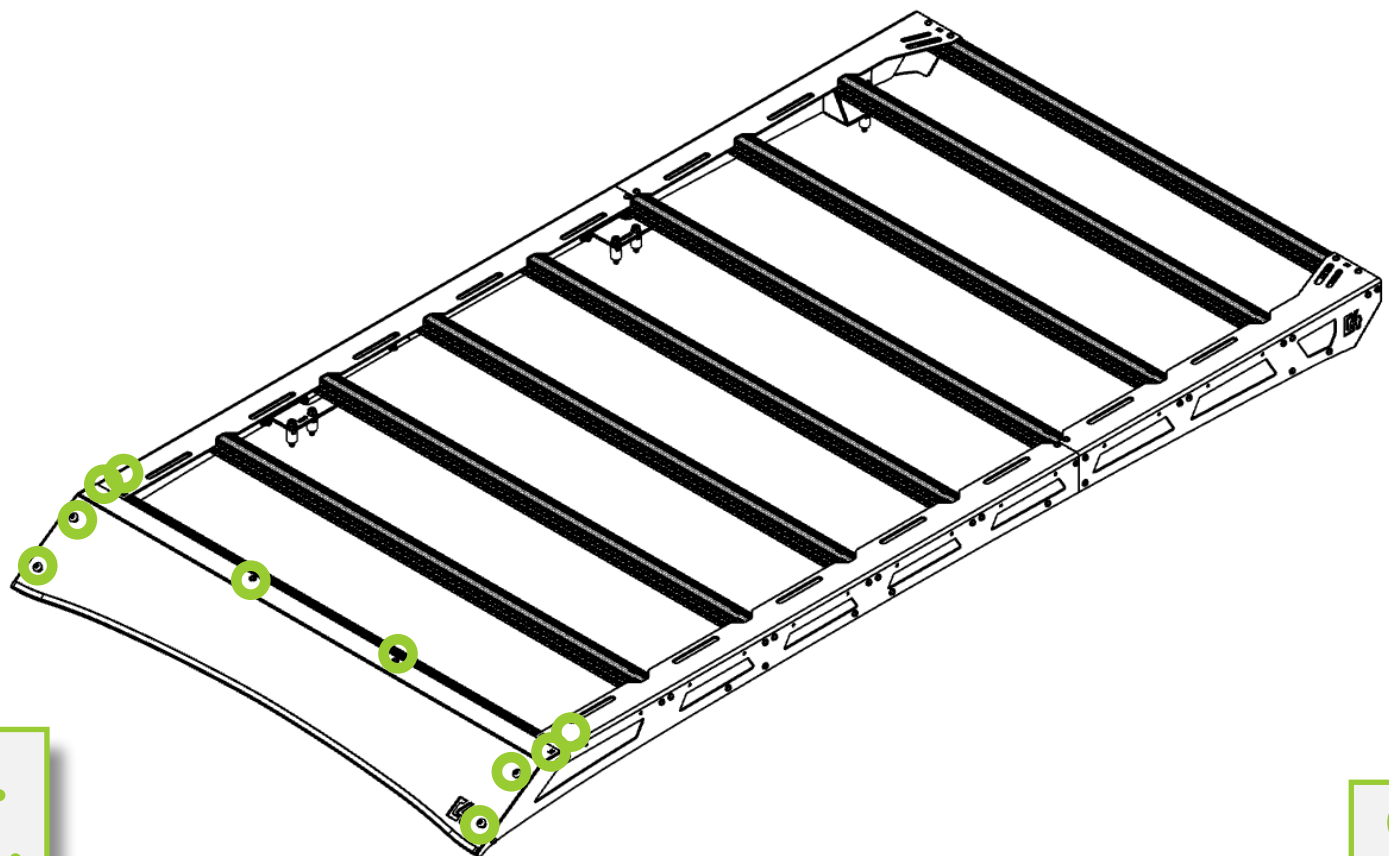

E.
E1.
E2.

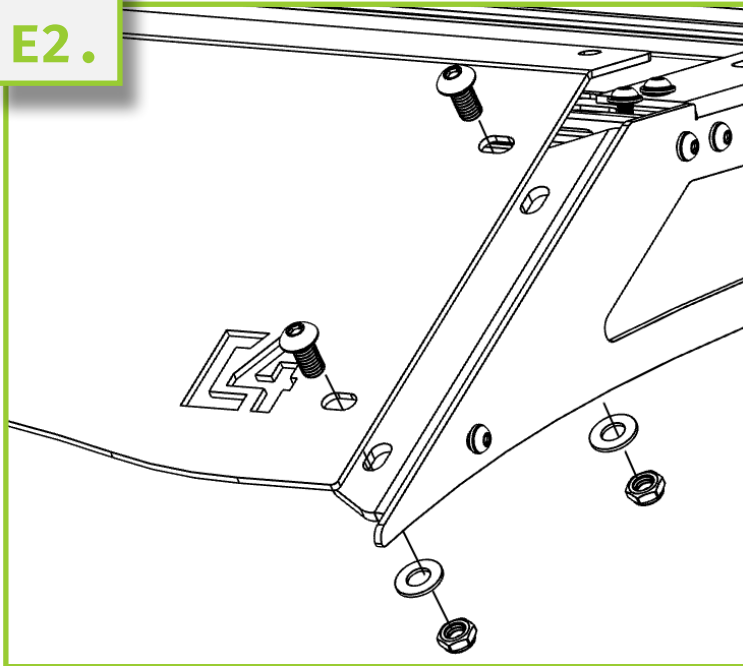

C.
C1.

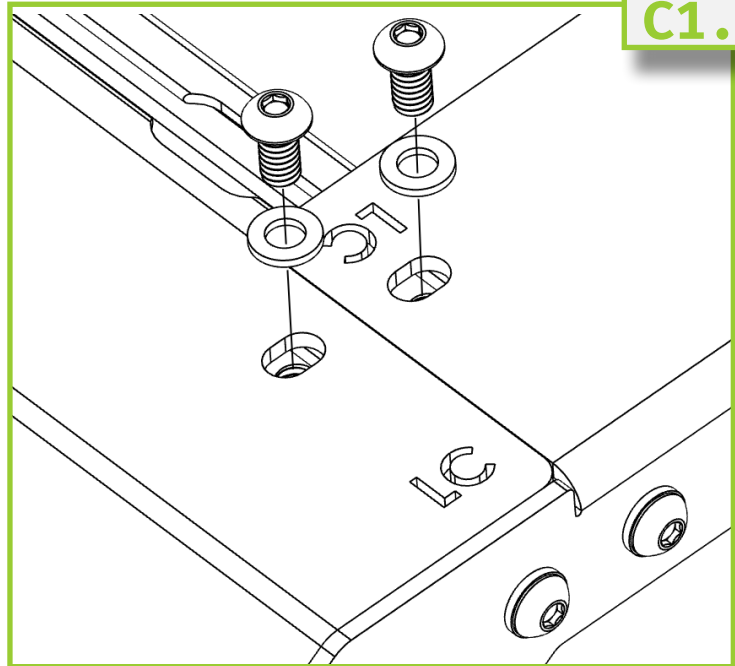

STEP 5

Using a 5/32 allen and the provided hardware (C, C1). Secure the back rail to the side panels using the T-nuts installed on **step 2**. (Repeat on the other side)

TECH TIP: Apply blue loctite to all hardware.

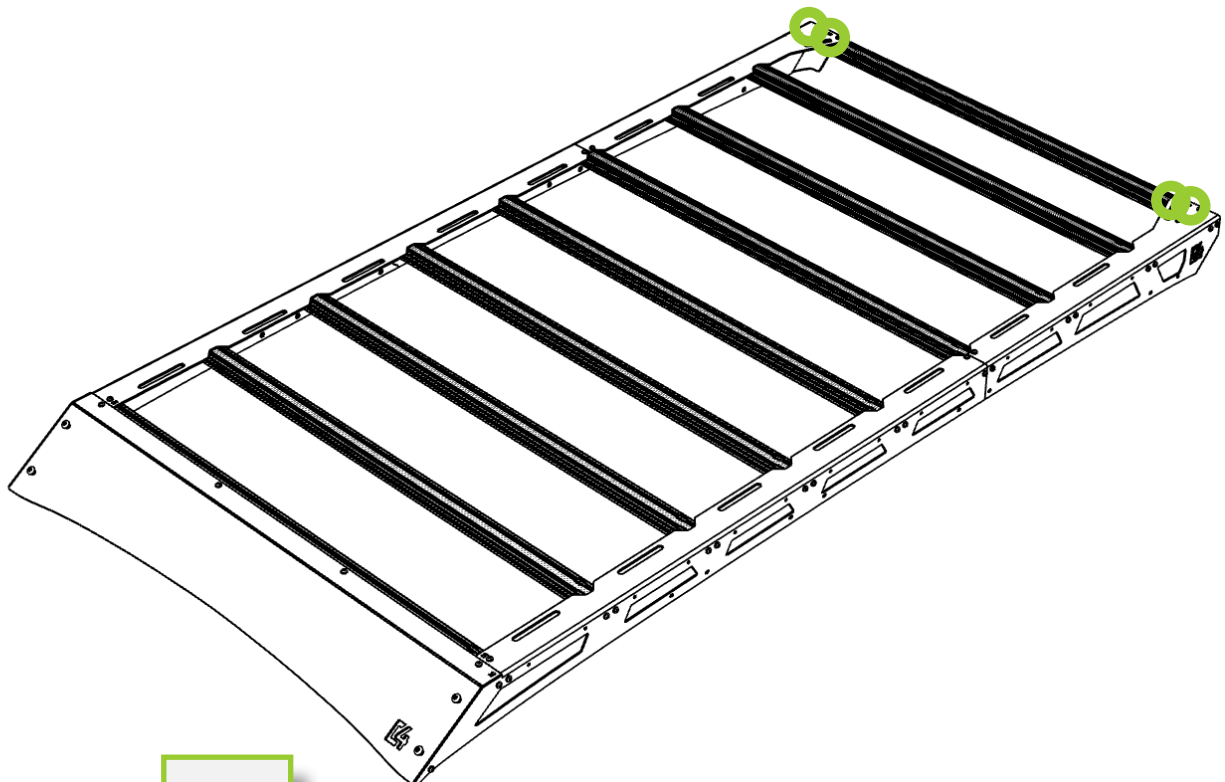

C.
C1.

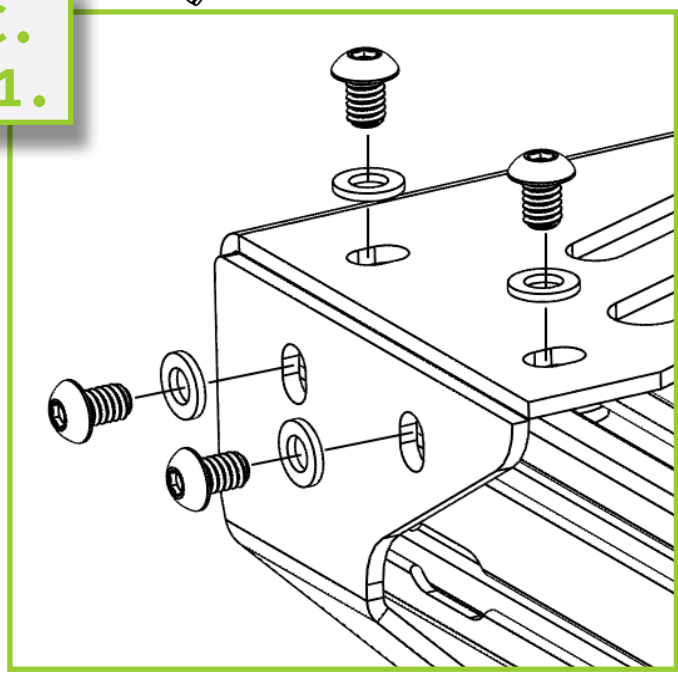

- B: 1/4-20 X 3/4" BUTTON HEAD BOLT (12X)
- C: 1/4-20 X 1/2" BUTTON HEAD BOLT (6X)
- C1: M6 FLAT WASHER (12X)
- C2: 1/4" FLAT WASHER (12X)
- C3: 1/4-20 NYLON LOCK NUT (12X)

STEP 6

Using a 5/32 allen, a 7/16 wrench and the provided hardware (B, C, C1, C2, C3), Install the front and rear mounting brackets as shown below. (Leave hardware loose at this time.)

TECH TIP: Apply blue loctite to all non-locking hardware.

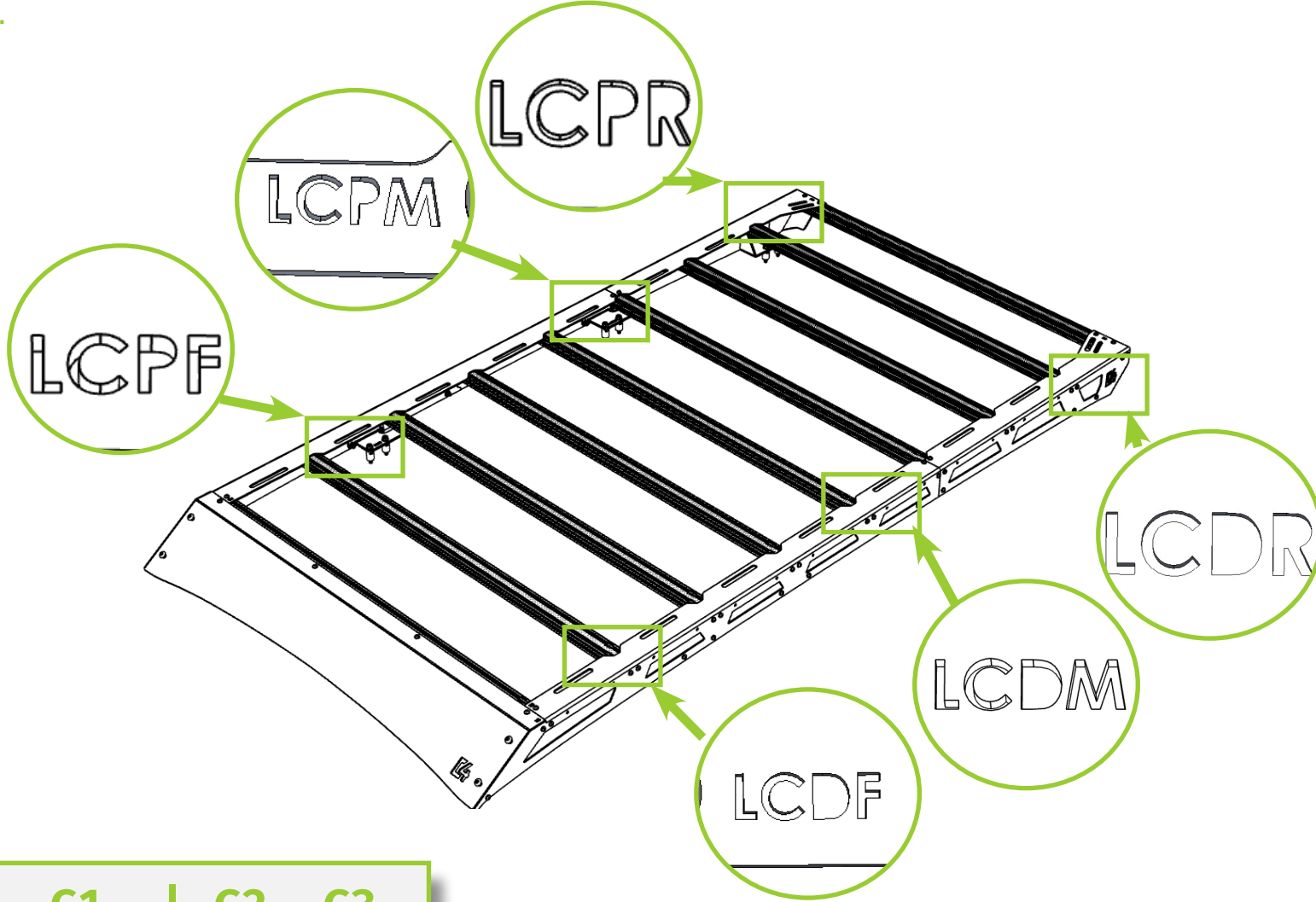

B. C1. | C2. C3.

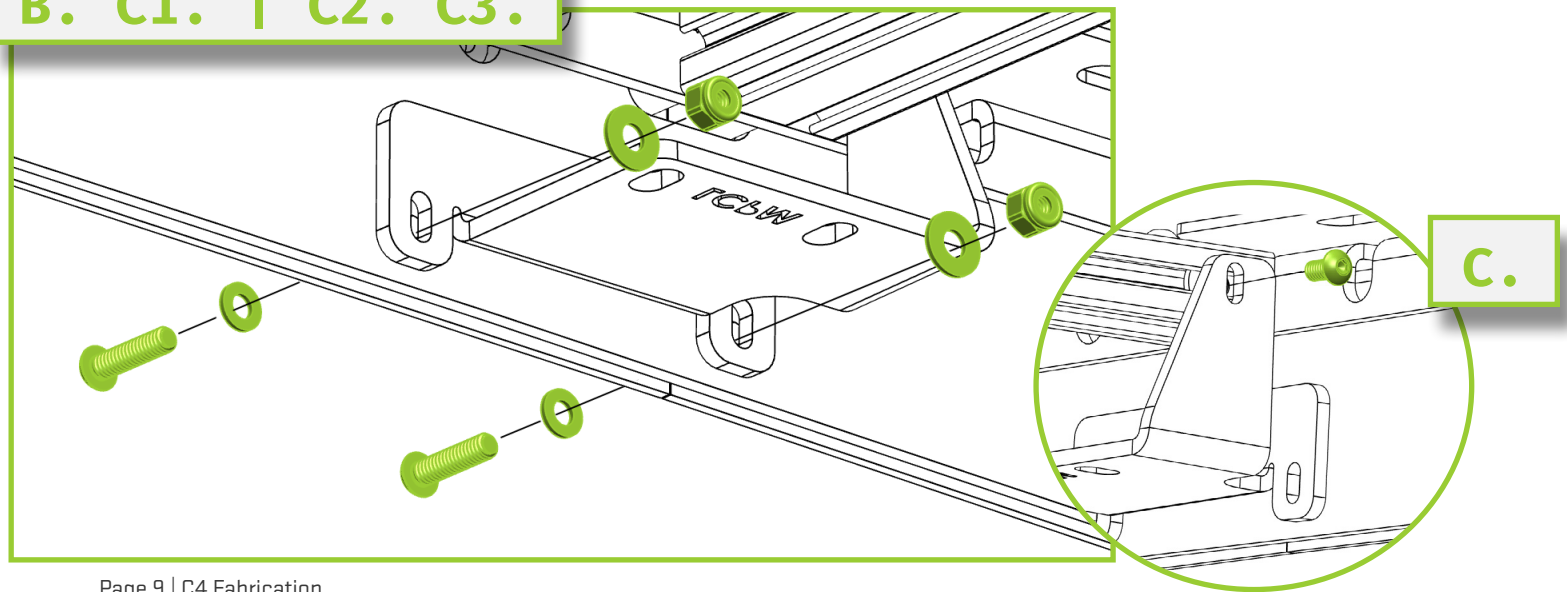

STEP 7

Using a 5/32 allen and a 7/16 wrench install the provided hardware **(B, C1, C2, C3)** as shown below.

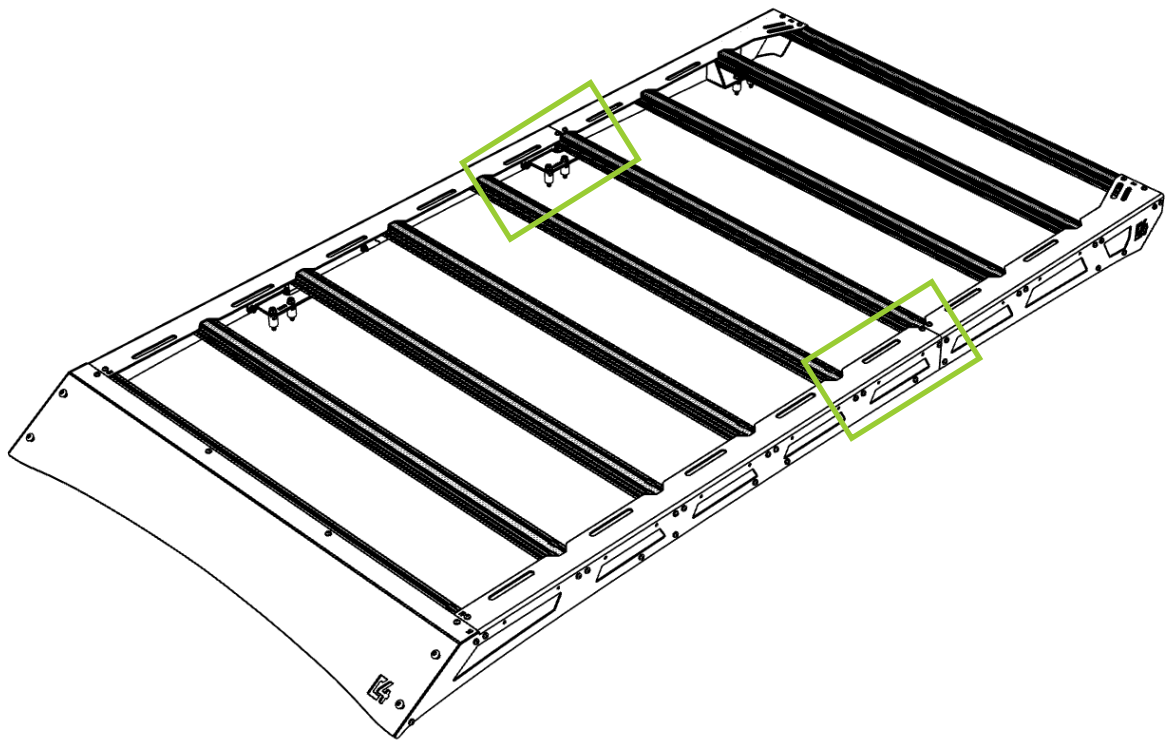

- B.
- C1.
-
- C2.
- C3.

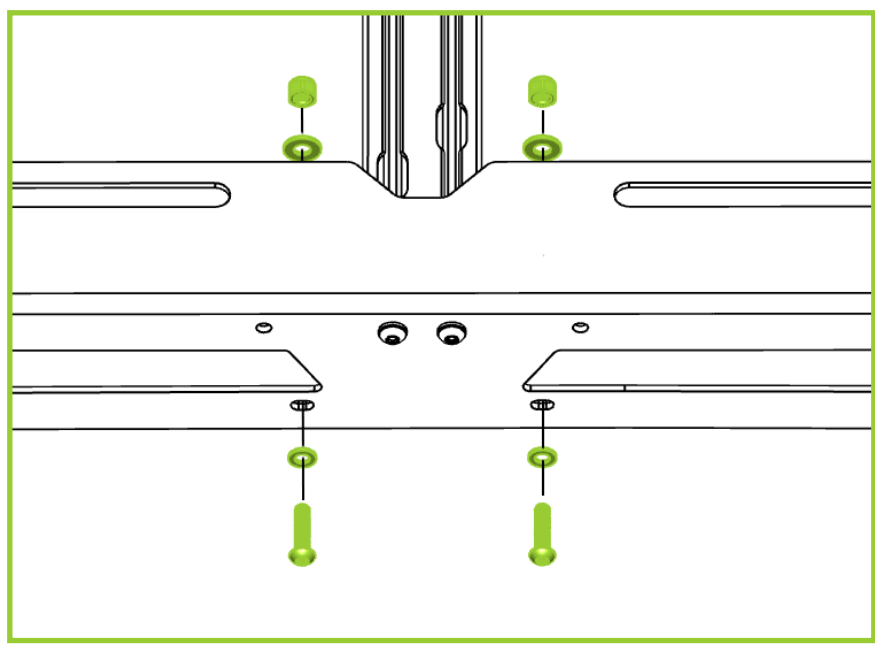

STEP 8

Install the rubber gasket (H) as shown below, with the bulb side of the gasket down. Trim length for desired fit..

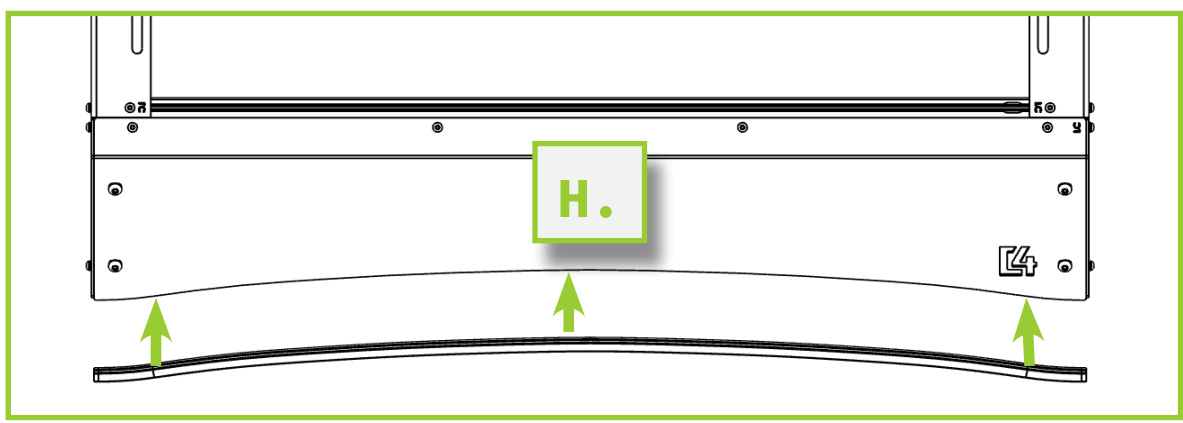
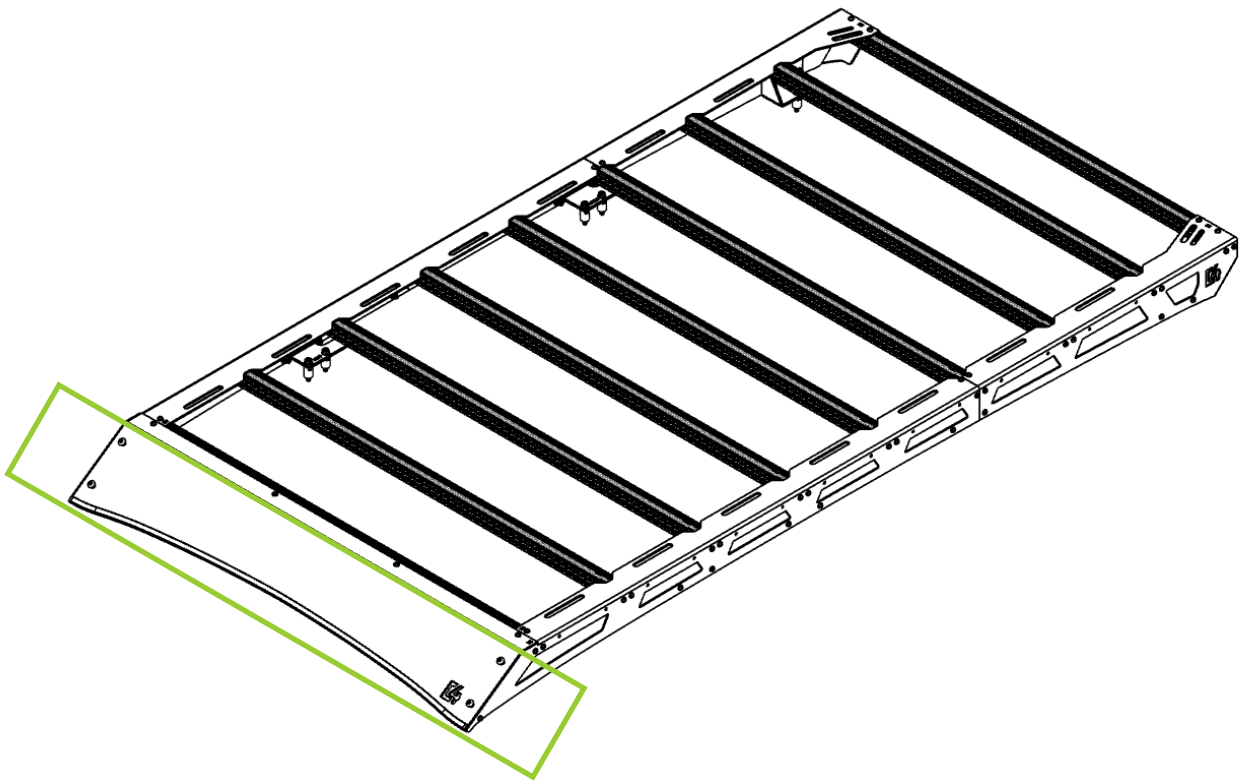

STEP 9

Remove the OEM roof rack caps by using a pry tool of your choice.
(TECH TIP: Use a plastic pry tool so you do not damage the paint)



STEP 10

Remove the OEM roof rack caps by using a pry tool of your choice.
(TECH TIP: Use a plastic pry tool so you do not damage the paint)



STEP 11

Using a 12mm socket remove the mounting bolts.



STEP 12

- Using the provided hardware (G), apply silicone onto the bottom of the aluminum spacer and BLUE LOCTITE to the threads. (Ensure you apply these only on the bottom end of the spacers)
- You can now install the provided hardware (G) into the holes located from step 9 & 10 using a 9/16 wrench. ****DO NOT OVER TIGHTEN****

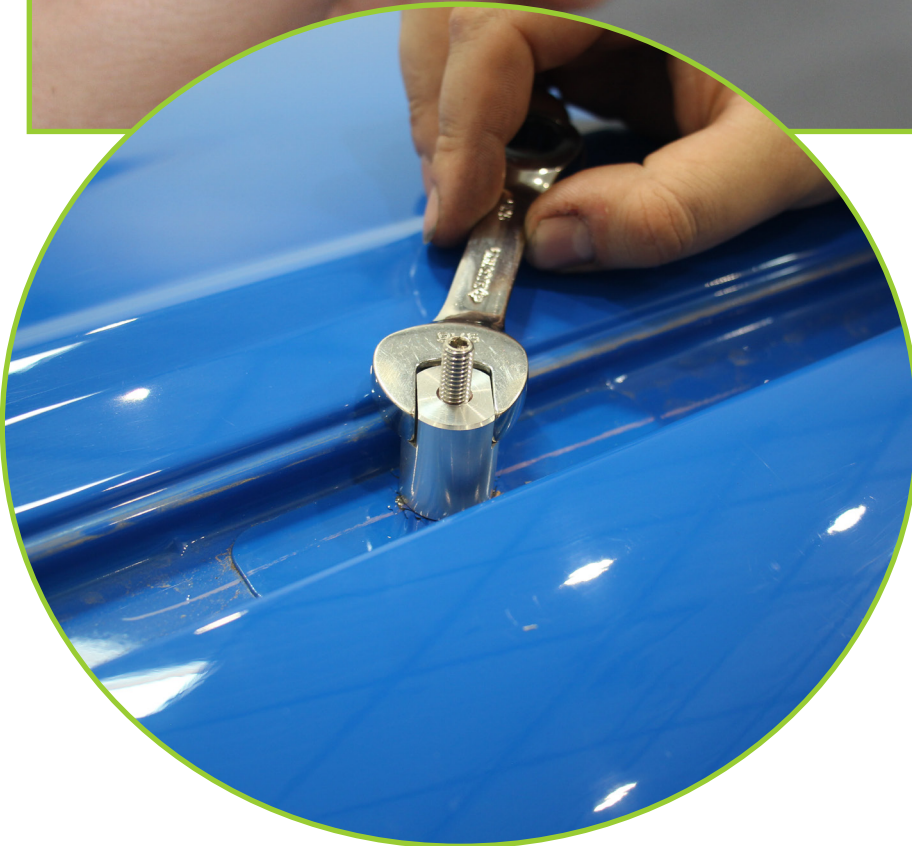

STEP 13

With a helping hand, install the roof rack onto the aluminum studs from **step 12** with the provided hardware **(G)** and a 13mm wrench. Center the roof rack on the truck then tighten hardware. Then set desired height and tighten the mounting brackets from **step 6** to the side panels.

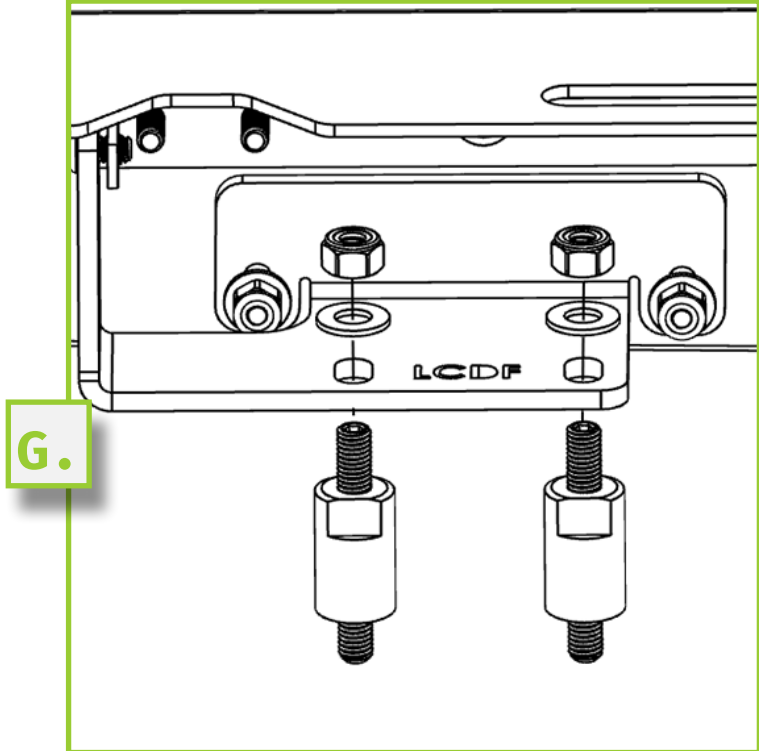



QUESTIONS OR CONCERNS?

CALL: 1-605-721-2911 OR EMAIL: sales@c4fabrication.com